Geometry Activities for Middle Grades Teachers

Bart Snapp and Brad Findell

January 11, 2021

Contents

| | | |
|------------|---|-----------|
| I | Proof by Pictures | 5 |
| 1 | It's What the Book Says | 6 |
| 2 | Forget Something? | 9 |
| 3 | Measuring Area | 11 |
| 4 | Suitable Precision in Language and Notation | 14 |
| 5 | Tilted Square | 17 |
| 6 | Pythagorean Theorem | 18 |
| 7 | Angles in a Funky Shape | 21 |
| 8 | Trapezoid Area | 24 |
| | | |
| II | Constructions | 29 |
| 9 | Triangle Investigation | 30 |
| 10 | UnMessUpable Figures | 31 |
| 11 | Triangle Centers | 33 |
| 12 | Lines in Triangles | 36 |
| 13 | Isosceles Bisectors | 38 |
| 14 | About Medians | 42 |
| 15 | Verifying Our Constructions | 46 |
| 16 | Of Angles and Circles | 49 |
| 17 | More Circles | 53 |
| 18 | Quadrilateral Diagonals | 58 |
| | | |
| III | Congruence and Similarity | 60 |
| 19 | Congruence via Transformations | 61 |
| 20 | More Transformations | 66 |
| 21 | Symmetries | 68 |
| 22 | Congruence Criteria | 71 |
| 23 | Parallels | 77 |

| | | |
|----|----------------------------------|-----|
| 24 | Midsegments | 80 |
| 25 | Similarities | 82 |
| 26 | Side-Splitter Theorems | 88 |
| 27 | Trigonometry Checkup | 95 |
| 28 | Please be Rational | 99 |
| 29 | Rep-Tiles | 101 |
| 30 | Rep-Tiles Repeated | 104 |
| 31 | Scaling Area | 108 |
| 32 | Turn Up the Volume! | 110 |

IV Coordinates 116

| | | |
|----|---|-----|
| 33 | Coordinate Constructions | 117 |
| 34 | Bola, Para Bola | 120 |
| 35 | More Medians | 122 |
| 36 | Constructible Numbers | 126 |
| 37 | Constructible Numbers, Part 2 | 129 |
| 38 | Impossibilities | 133 |

V Functions 135

| | | |
|----|--|-----|
| 39 | Area and Perimeter | 136 |
| 40 | Reading Information from a Graph | 140 |
| 41 | Circular Trigonometry | 143 |
| 42 | Parametric Equations | 147 |
| 43 | Parametric Plots of Circles | 151 |
| 44 | Eclipse the Ellipse | 154 |

VI City Geometry 157

| | | |
|----|--|-----|
| 45 | Taxicab Distance | 158 |
| 46 | Understanding and Using Absolute Value | 160 |
| 47 | The Path Not Taken | 163 |
| 48 | Midsets Abound | 165 |

49 Tenacity Paracity 168

Part I

Proof by Pictures

1 It's What the Book Says

Writing and using careful definitions to describe relationships among special quadrilaterals.

Problem 1 Do the following task fifth-grade task: Put the terms **square**, **rhombus**, and **parallelogram** in the Venn diagram below.

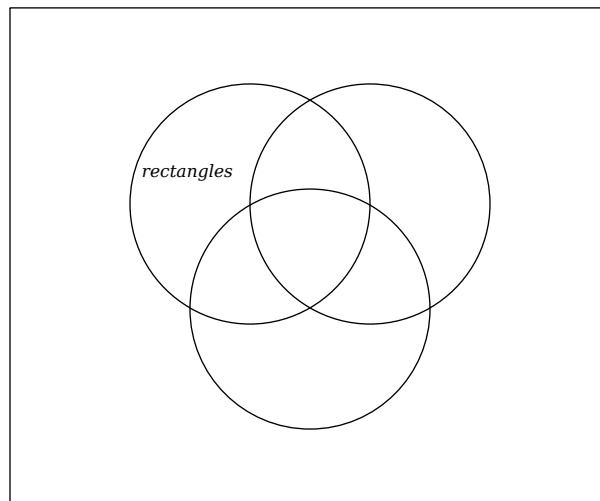

Problem 2 Critique the task above based on mathematical content.

Problem 3 Supposing we know that a quadrilateral is a polygon with four sides, write clear and succinct definitions of each of the following terms:

- (a) *A rectangle is a quadrilateral*
 - (b) *A parallelogram is a quadrilateral*
 - (c) *A rhombus is a quadrilateral*
 - (d) *A square is a quadrilateral*
 - (e) *A trapezoid is a quadrilateral*
 - (f) *A kite is a quadrilateral*
-

Problem 4 Create a Venn diagram showing the correct relationships among these quadrilaterals. Be ready to present and defend your diagram to your peers.

2 Forget Something?

We study sets, fundamental objects in mathematics.

Problem 5 *Draw a Venn diagram with one set. List every possible relationship between an element and this set.*

Problem 6 *Draw a Venn diagram with two intersecting sets. List every possible relationship between an element and these sets.*

Problem 7 *Draw a Venn diagram with three intersecting sets. List every possible relationship between an element and these sets.*

Problem 8 Describe and explain any patterns you see occurring.

Problem 9 Draw a Venn diagram with four intersecting sets. List every possible relationship between an element and these sets.

Problem 10 Are you **sure** that your diagram for Problem 1 is correct? If so explain why. If not, draw a correct Venn diagram.

3 Measuring Area

We measure the area of triangles.

Problem 11 *Three congruent triangles are shown below.*

- (a) *For each triangle, choose a base and use a ruler to draw carefully the corresponding height to that base. (Choose bases of different lengths.) Remember: A height is measured on a line that is perpendicular to a base and containing the opposite vertex.*
- (b) *Measure the heights and bases accurately, and compute the area of each triangle.*
- (c) *What do your results demonstrate about the formula for the area of a triangle?*

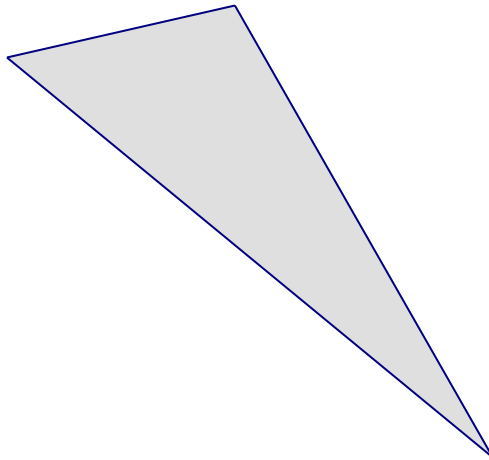

3 Measuring Area

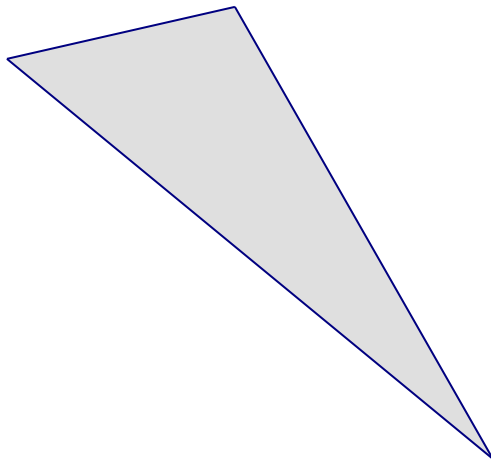
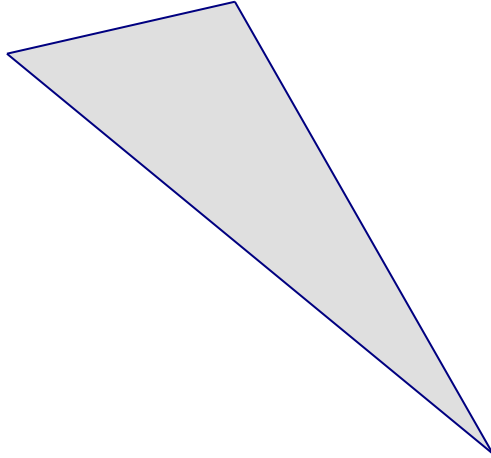

4 Suitable Precision in Language and Notation

We discuss language for talking about geometry.

Geometry is about points, lines, and other figures made up of points. Points can have coordinates, which are numbers, but we save these approaches for later in the course.

Even without coordinates, geometry involves numbers, especially as measures of lengths, angles, and areas.

Problem 12 *Let M be the midpoint of \overline{AB} .*

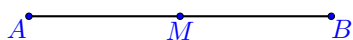

Mark each statement T (true) or F (false). Briefly explain your reasoning.

- (a) $\overline{AB} = \overline{BA}$
- (b) $AB = BA$
- (c) $\overline{AM} = \overline{MB}$
- (d) $AM = MB$

Problem 13 *Describe the geometric distinction between a segment and its length. How are the two usually denoted differently?*

Problem 14 Compare $\angle CAB$ and $\angle FDE$ in the figure below.

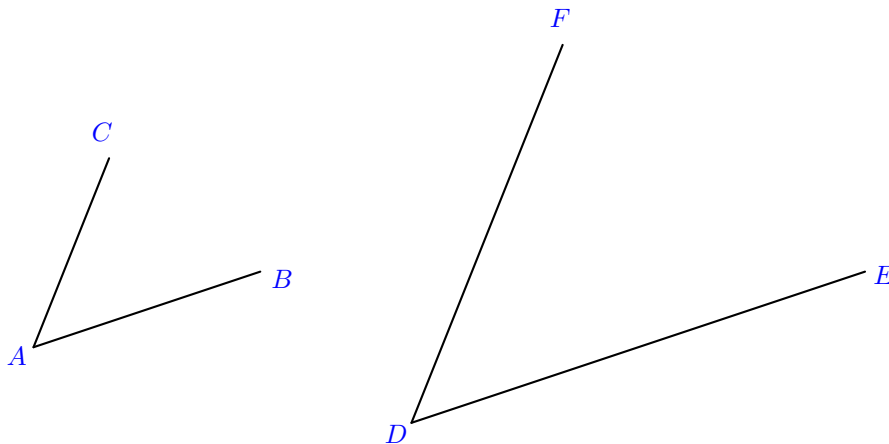

Mark each statement T (true) or F (false). Briefly explain your reasoning.

- (a) $\angle CAB = \angle BAC$
- (b) $\angle CAB = \angle FDE$
- (c) $m\angle CAB < m\angle FDE$
- (d) $m\angle CAB = m\angle FDE$

Problem 15 There are (at least) two ways of thinking about angles.

- (a) Use precise language to describe an angle as a set of points.

- (b) Use precise language to describe an angle as an amount of turning.

4 Suitable Precision in Language and Notation

Problem 16 Describe the geometric distinction between an angle and its measure. How are the two usually denoted differently? And how do your answers relate to the previous problem?

Problem 17 Use your meanings for angles to improve upon the following imprecise statements.

| <i>Statement</i> | <i>Improved Version</i> |
|---|-------------------------|
| <i>A triangle has 180°.</i> | |
| <i>A line measures 180°.</i> | |
| <i>A circle is (or has) 360°.</i> | |

5 Tilted Square

We find the area of a tilted square.

Problem 18 In the diagram below, the dots are 1 centimeter apart, both vertically and horizontally. The vertices of the square all lie exactly on such dots. Find the area of the square, without computing the length of the side of the square. Explain your method.

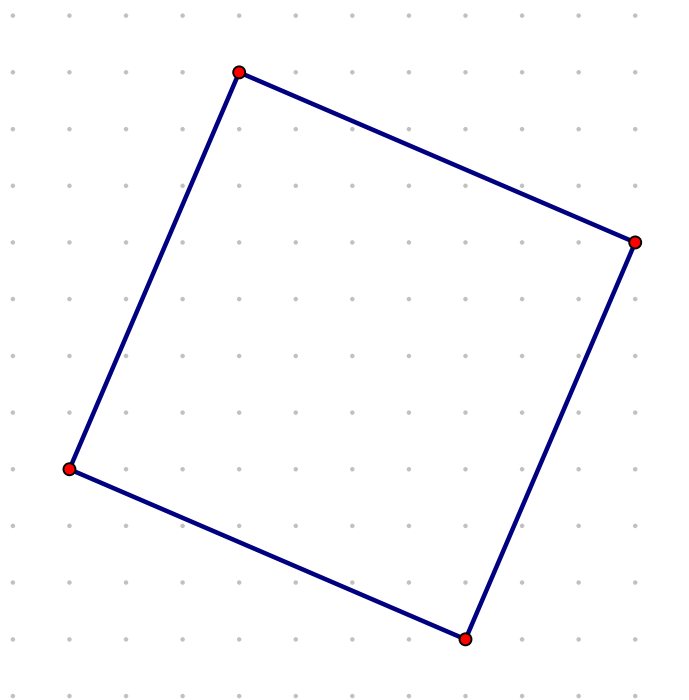

6 Pythagorean Theorem

We prove the most famous theorem of all, the Pythagorean Theorem.

Problem 19 Give two explanations of how the following picture “proves” the Pythagorean Theorem, one using algebra and one without algebra.

• CCSS 8.G.6. Explain a proof of the Pythagorean Theorem and its converse.

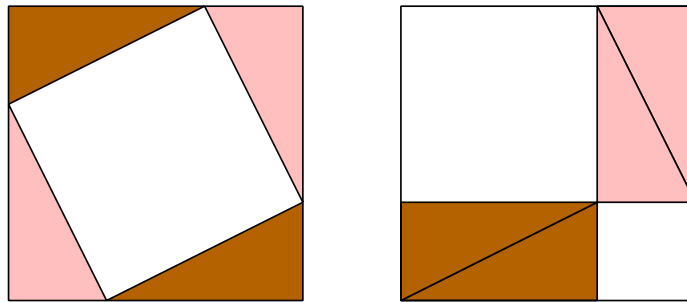

Problem 20 *State the converse of the Pythagorean Theorem and prove it.*

7 Angles in a Funky Shape

Let's put your knowledge of interior angles to a test.

We are going to investigate the sum of the interior angles of a funky shape.

Problem 21 Using a protractor, measure the interior angles of the crazy shape below:

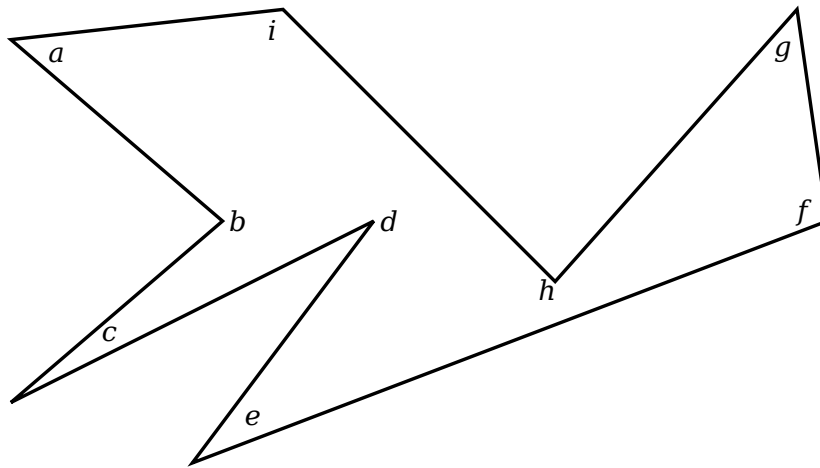

Use this table to record your findings:

| <i>a</i> | <i>b</i> | <i>c</i> | <i>d</i> | <i>e</i> | <i>f</i> | <i>g</i> | <i>h</i> | <i>i</i> |
|----------|----------|----------|----------|----------|----------|----------|----------|----------|
| | | | | | | | | |

Problem 22 Find the sum of the interior angles of the polygon above.

Author(s): Jenny Sheldon, Bart Snapp, and Brad Findell

Problem 23 *What should the sum be? Explain your reasoning. (You might find it useful to consider some of the angles to be “reflex angles.” Which ones?)*



8 Trapezoid Area

We investigate trapezoids and how to compute their area.

Problem 24 Explain how the following picture “proves” that the area of a right triangle is half the base times the height.

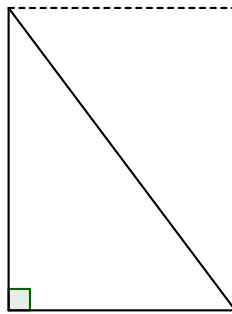

Problem 25 Suppose you know that the area of a **right** triangle is half the base times the height. Explain how the following picture “proves” that the area of **every** triangle is half the base times the height.

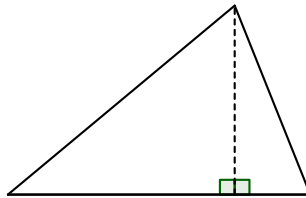

Problem 26 Now suppose that *Geometry Giorgio* attempts to solve a similar problem. Again knowing that the area of a right triangle is half the base times the height, he draws the following picture:

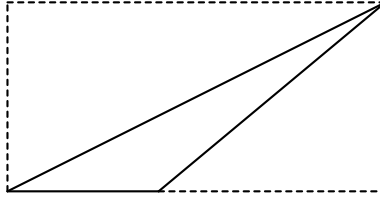

Geometry Giorgio states that the diagonal line cuts the rectangle in half, and thus the area of the triangle is half the base times the height. Is this correct reasoning? If so, give a complete explanation. If not, give correct reasoning based on *Geometry Giorgio's* picture.

Problem 27 Now we explore several ways of justifying the formula for the area of a trapezoid, as labeled below.

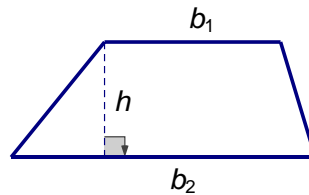

Complete the table on the following page so that, in each row, the explanation, the geometric figure, and the algebraic formula together describe a way of computing the area. For comparison purposes, each illustration should include a trapezoid congruent to the trapezoid above.

All of the area formulas will, of course, be equivalent to one another as expressions. But each way of expressing the area will make the most sense with figure and the explanation from the same row.

8 Trapezoid Area

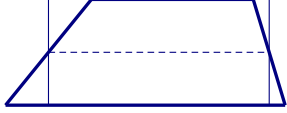
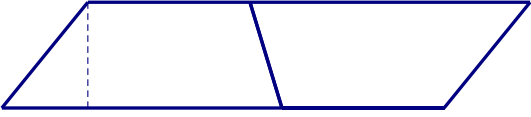
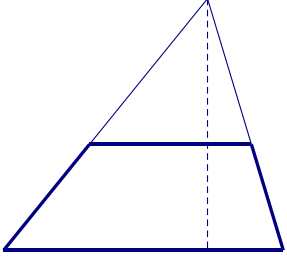
| Explanation | Figure | Area Formula |
|--|--|-------------------------------------|
| <p>Rectangle with width that is the average of the bases.</p> |  | $\left(\frac{b_1 + b_2}{2}\right)h$ |
| |  | |
| <p>Two triangles with the same height and different bases.</p> | | |
| | | $(b_1 + b_2)\frac{h}{2}$ |
| |  | |

Part II

Constructions

9 Triangle Investigation

Find triangles given various conditions.

Problem 28 Draw triangles satisfying the conditions given below. You may use whatever tools you like (e.g., ruler, protractor, compass, sticks, tracing paper, or Geogebra).[•]

In each part, use reasoning to determine whether the information provided determines a unique $\triangle ABC$, more than one triangle, or no triangle.

Note: To check to see if two triangles are the same, attempt to lay one directly on top of the other.

- (a) $AB = 4$ and $BC = 5$
- (b) $m\angle CAB = 25^\circ$, $m\angle ABC = 75^\circ$, $m\angle BCA = 80^\circ$
- (c) $m\angle CAB = 25^\circ$, $m\angle ABC = 65^\circ$, $m\angle BCA = 80^\circ$
- (d) $AB = 4$, $m\angle BAC = 30^\circ$, $m\angle ABC = 45^\circ$
- (e) $AB = 4$, $BC = 5$, $m\angle ABC = 60^\circ$
- (f) $BC = 7$, $CA = 8$, $AB = 9$
- (g) $BC = 4$, $CA = 8$, $AB = 3$
- (h) $m\angle ABC = 45^\circ$, $BC = 8$, $CA = 12$
- (i) $m\angle ABC = 30^\circ$, $BC = 10$, $CA = 7$
- (j) $m\angle ABC = 60^\circ$, $BC = 10$, $CA = 3$

[•] CCSS 7.G.2. Draw (free-hand, with ruler and protractor, and with technology) geometric shapes with given conditions. Focus on constructing triangles from three measures of angles or sides, noticing when the conditions determine a unique triangle, more than one triangle, or no triangle.

10 UnMessUpable Figures

We model Euclidean constructions in dynamic geometry software.

Suppose we draw or construct a geometric figure (e.g., a square or an isosceles triangle) with pencil, paper, compass, and straightedge. If we want to compare to another example of that type of figure, we need to begin again from scratch. With dynamic geometry software (e.g., *Geogebra*, *Geometer's Sketchpad*, or *Cabri*), we can alter the original figure by “dragging” vertices and segments to create many other examples. For this to work properly, we want to *construct* the figure rather than merely *draw* it, so that a square, for example, remains a square even if we move its vertices. Some folks call such figures “UnMessUpable.”

Rules of Engagement:

- Before you begin, explore the menus and toolbars to see what the software provides.
- You may use tools that function as a compass or straight-edge would.
- You may use special tools (e.g., perpendicular bisector) that accomplish multistep compass-and-straightedge constructions in a single step.
- Do not use tools for transformations (e.g., translations, reflections, or rotations).
- Do not use tools that construct objects from measurements.

Begin each problem in a new sketch.

Problem 29 *Construct a segment between two points. Then construct an equilateral triangle with that segment as one of its sides. Be sure that the triangle remains equilateral when you drag its vertices. (Note: Do not use a “regular polygon” tool.)*

Problem 30 *Construct a segment between two points. Then construct a square with that segment as one of its sides. Be sure that it remains a square when you drag its vertices. (Note: Do not use a “regular polygon” tool.)*

Author(s): Bart Snapp and Brad Findell

Problem 31 Construct an UnMessUpable parallelogram. (Hint: Think about the definition.)

Problem 32 Construct a rectangle that, through dragging, can be long and thin, short and fat, or anything in between, but that is always a rectangle.

Problem 33 Copy a segment. Construct a segment and a line. Then copy the segment onto the line. Hide the line so that the segment alone is clear. Then drag the vertices that determine the initial segment to show that the copy is always congruent to it.

Problem 34 Copy an angle. Using the ray tool, construct an angle and a separate ray. Then copy the angle onto the other ray. Drag the vertices that determine the first angle to show that the copy is always congruent to it.

Problem 35 Construct a capital H so that the midline is always the perpendicular bisector of both sides.

Problem 36 Construct a quadrilateral so that one pair of opposite sides is always congruent.

11 Triangle Centers

We investigate different “centers” for triangles.

In this activity, we use Geogebra to explore the basic lines, centers, and circles related to triangles.

Problem 37 Here are some easy questions to get the brain-juices flowing!

- Place two points randomly in the plane. Do you expect to be able to draw a single line that connects them?
- Place three points randomly in the plane. Do you expect to be able to draw a single line that connects them?
- Place two lines randomly in the plane. How many points do you expect them to share?
- Place three lines randomly in the plane. How many points do you expect all three lines to share?
- Place two points randomly in the plane. Will you always be able to draw a circle containing these points?
- Place three points randomly in the plane. Will you (almost!) always be able to draw a circle containing these points? If no, why not? If yes, how do you know?
- Place four points randomly in the plane. Do you expect to be able to draw a circle containing all four at once? Explain your reasoning.

Definition 1. Three (or more) distinct lines are said to be **concurrent** if they have a point in common.

Problem 38 In Geogebra, draw a triangle. Now construct the perpendicular bisectors of the sides. Describe what you notice. Does this work for every triangle?

Problem 39 In a new Geogebra sketch, draw a triangle. Now bisect the angles. Describe what you notice. Does this work for every triangle?

Author(s): Bart Snapp and Brad Findell

Problem 40 In a new Geogebra sketch, draw a triangle. Now construct the lines containing the altitudes. Describe what you notice. Does this work for every triangle?

Problem 41 In a new Geogebra sketch, draw a triangle. Now construct the medians. Describe what you notice. Does this work for every triangle?

Problem 42 The **circumcircle** of a triangle contains all three vertices of the triangle. The center of the circumcircle is called the **circumcenter**. Find the circumcenter on your sketch with the three perpendicular bisectors, and construct the circumcircle.

Problem 43 The **incircle** of a triangle is tangent to all three sides of the triangle. The center of the incircle is called the **incenter**. Find the incenter on your sketch with three angle bisectors. Construct the incircle. (Hint: To find the radius of the incircle, you will need to find the distance from the incenter to one of the sides of the triangle.)

Problem 44 The other “centers” of a triangle are called the **centroid** and the **orthocenter**. Make a thoughtful guess about how these correspond to the medians and the lines containing the altitudes.

Problem 45 Fill in the following handy chart summarizing what you found above.

| | <i>Associated point?</i> | <i>Always inside triangle?</i> | <i>Meaning?</i> |
|-----------------------------------|--------------------------|--------------------------------|-----------------|
| <i>perpendicular bisectors</i> | | | |
| <i>angle bisectors</i> | | | |
| <i>lines containing altitudes</i> | | | |
| <i>lines containing medians</i> | | | |

Be sure to put this in a safe place like in a safe, or under your bed.



12 Lines in Triangles

We think about some special lines in triangles.

Two copies of a triangle are shown below. In each triangle, **draw carefully** the designated lines. *Construction is not necessary: Careful measurements are allowed.*

Problem 46 In the triangle below, draw the median from B to \overline{AC} , the altitude from B to \overline{AC} , the angle bisector of $\angle B$, and the perpendicular bisector of \overline{AC} .

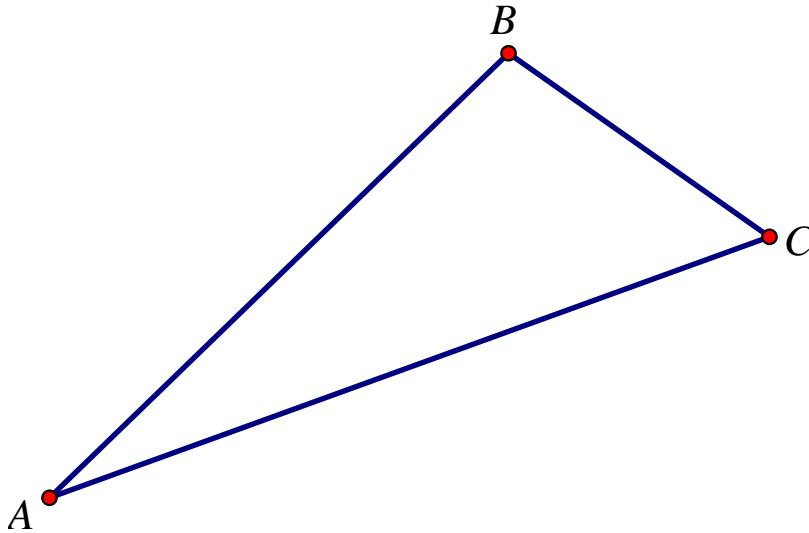

Problem 47 In the triangle below, draw the median from C to \overline{AB} , the altitude from C to \overline{AB} , the angle bisector of $\angle C$, and the perpendicular bisector of \overline{AB} .

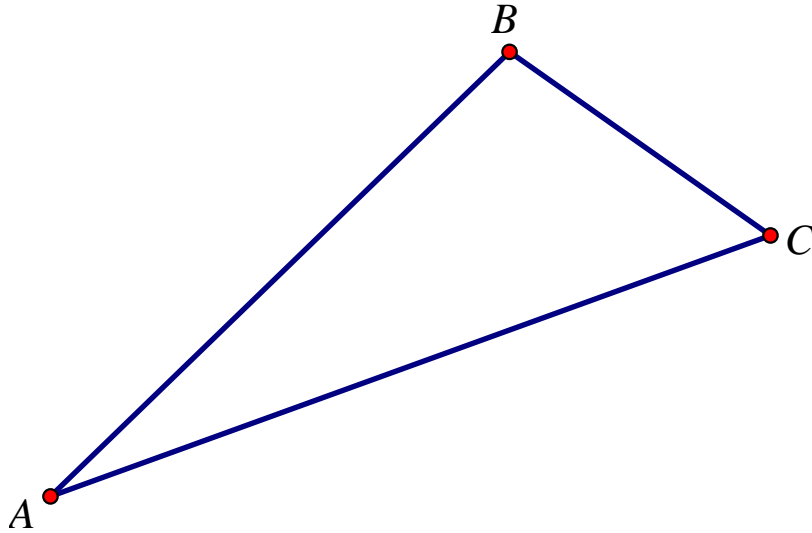

Problem 48 In each triangle, you should have drawn four different lines. What might you say about a triangle for which two or more of these lines turn out to be the same?

13 Isosceles Bisectors

We think about isosceles triangles.

Theorem 1 (Isosceles Triangle Theorem). *If two sides of a triangle are congruent, then the angles opposite those sides are congruent.*

Problem 49 *Prove the Isosceles Triangle Theorem. (Hint: In a previous activity, you noticed that in most triangles the median, perpendicular bisector, angle bisector, and altitude to a side lie on four different lines. So if you draw a new line in your diagram, be sure to decide which of these lines you are drawing.)*

Problem 50 *Use your proof to show that, in an isosceles triangle, a median, perpendicular bisector, angle bisector, and altitude turn out to be the same line.*

Problem 51 *Prove the Isosceles Triangle Theorem without drawing another line. Hint: Is there a way in which the triangle is congruent to itself?*

Problem 52 *State the converse of the Isosceles Triangle Theorem and prove it.*

Problem 53 *Prove that the points on the perpendicular bisector of a segment are exactly those that are equidistant from the endpoints of the segment. Note that the phrase exactly those requires that we prove a simpler statement as well as its converse:*

- (a) *Prove that a point on the perpendicular bisector of a segment is equidistant from the endpoints of that segment.*
- (b) *Prove that a point that is equidistant from the endpoints of a segment lies on the perpendicular bisector of that segment.*

Problem 54 *Prove that the perpendicular bisectors of a triangle are concurrent. Hint: Name the intersection of two of the perpendicular bisectors and then show that it must also lie on the third one. (This is a standard approach for showing the concurrency of three lines.)*

Problem 55 Draw a line (neither horizontal nor vertical) and a point not on the line. Describe how to find the exact distance from the point to the line.



Problem 56 Prove that the points on an angle bisector are exactly those that are equidistant from the sides of the angle.



Problem 57 Prove that the angle bisectors of a triangle are concurrent.



14 About Medians

We explore several ways of thinking about the medians of triangles.

Problem 58 On cardstock, use a ruler to draw a medium-sized, non-right, non-isosceles triangle, and then cut it out as accurately as you can. Draw two of the medians on the cutout triangle. Draw the third median to make sure they are concurrent.

- Using a ruler, try balancing the triangle along each median. (Ask a partner to hold the ruler steady.)
- Now try balancing the triangle along a line that is not a median. How does your line relate to the intersection of the medians? Explain why this makes sense.
- Try balancing the triangle from a string at the intersection of the medians. (Use the point of your compass to make a hole in the cardstock.)

Problem 59 Imagine stacking toothpicks in a triangle, as shown below.

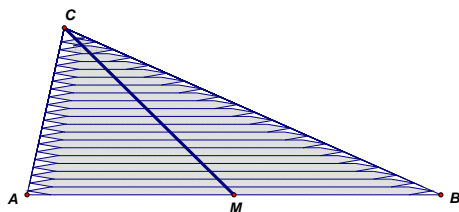

- Explain, using toothpicks, why the triangle would balance on a ruler placed along the median \overline{CM} .

- (b) *Explain, using a different collection of toothpicks, why the triangle would balance along the median to side \overline{AC} . Describe how the toothpicks would need be placed, relative to side \overline{AC} .*
- (c) *The two medians will intersect at a point. Explain why the triangle (without toothpicks) should balance from a string or on a pencil point at the intersection of the two medians.*
- (d) *Use a balancing argument to explain why the third median should contain the intersection of the first two.*

Problem 60 The next problem uses the midsegment theorem. A midsegment is a line joining the midpoints of two sides. Draw carefully a triangle and a midsegment, and use it to make a conjecture about what the midsegment theorem says. (We will prove the theorem later.)

Problem 61 Use the picture below to show that a pair of medians intersects at a point $\frac{2}{3}$ of the way from the vertex to the opposite side. Then use that fact to argue that the three medians must be concurrent.

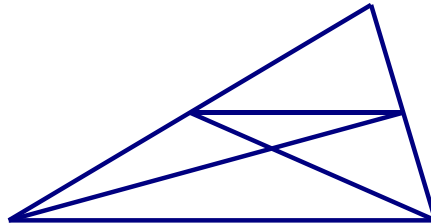

Problem 62 *Imagine a triangle made of nearly weightless material with one-pound weights placed at each of the vertices, A , B , and C .*

- (a) *Explain why the triangle will balance on a ruler along the median to side \overline{AB} .*
- (b) *Explain why the triangle will continue to balance along the median when the masses at A and B are both moved to the midpoint of \overline{AB} .*
- (c) *Now imagine trying to balance the triangle at a single point along the median. Where will it balance? Use the phrase “weighted average” to explain your reasoning.*

Problem 63 *Using the picture below, explain why the medians of the large triangle are also medians of the medial triangle. Then explain how repeating this process indefinitely proves that the medians are concurrent.*

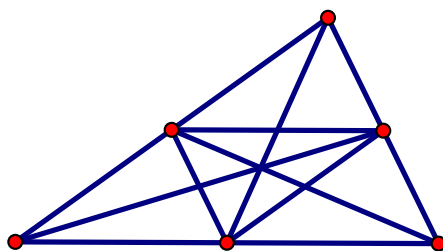

15 Verifying Our Constructions

We use basic theorems to verify our Euclidean compass-and-straightedge constructions.

When we do our compass-and-straightedge constructions, we should take care to verify that they actually work as advertised. We'll walk you through this process. To start, remember what a circle is:

Definition 2. A *circle* is the set of points that are a fixed distance from a given point.

Problem 64 *Is the center of a circle part of the circle? Explain.*

Problem 65 *Construct an equilateral triangle. Why does this construction work?*

Now recall the SSS Theorem:

Theorem 2 (SSS). *Specifying three sides uniquely determines a triangle.*

Problem 66 *Now we'll analyze the construction for copying angles.*

- (a) *Use a compass and straightedge construction to duplicate an angle. Explain how you are really just “measuring” the sides of some triangle.*
- (b) *In light of the SSS Theorem, can you explain why the construction used to duplicate an angle works?*

Problem 67 *Now we'll analyze the construction for bisecting angles.*

- (a) *Use compass and straightedge construction to bisect an angle. Explain how you are really just constructing (two) isosceles triangles. Draw these isosceles triangles in your figure.*
- (b) *Find two more triangles on either side of your angle bisector where you may use the SSS Theorem to argue that they have equal side lengths and therefore equal angle measures.*
- (c) *Can you explain why the construction used to bisect angles works?*

Recall the SAS Theorem:

Theorem 3 (SAS). *Specifying two sides and the angle between them uniquely determines a triangle.*

Problem 68 Now we'll analyze the construction for bisecting segments.

- (a) Use a compass and straightedge construction to bisect a segment. Explain how you are really just constructing two isosceles triangles.
- (b) Note that the bisector divides each of the above isosceles triangles in half. Find two triangles on either side of your bisector where you may use the SAS Theorem to argue that they have equal side lengths and angle measures.
- (c) Can you explain why the construction used to bisect segments works?

Problem 69 Now we'll analyze the construction of a perpendicular line through a point not on the line.

- (a) Use a compass and straightedge construction to construct a perpendicular through a point. Explain how you are really just constructing an isosceles triangle.
 - (b) Find two triangles in your construction where you may use the SAS Theorem to argue that they have equal side lengths and angle measures.
 - (c) Can you explain why the construction used to construct a perpendicular through a point works?
-

16 Of Angles and Circles

We study central and inscribed angles.

In this activity we are going to look at pictures and see if we can explain how they “prove” theorems.

Theorem 4. *Any triangle inscribed in a circle and having the diameter as a side is a right triangle.*

Problem 70 *Can you tell me in English what this theorem says? Provide some examples of this theorem in action.*

Problem 71 *Here is a series of pictures, designed to be read from left to right.*

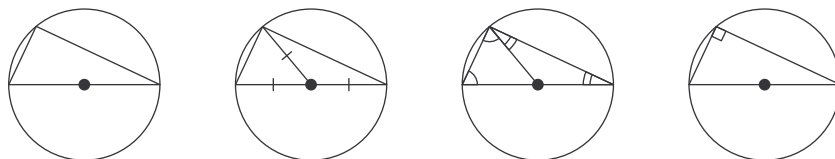

Explain how these pictures “prove” the above theorem. In the process of your explanation, you may need to label parts of the pictures and do some algebra.

Definition 3. A chord in a circle defines two arcs, each of which corresponds to a central angle. The measure of the arc is defined to be the measure of the corresponding central angle.

Problem 72 Can you tell me in English what this definition says? Use pictures to demonstrate what the fancy words mean.

Theorem 5. Given an arc of a circle, the central angle corresponding to this arc is twice any inscribed angle intercepting this arc.

I'll play nice here and give you a picture of this theorem in action:

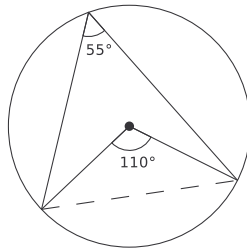

Problem 73 Can you tell me in English what this theorem says? Specifically, what is meant by *inscribed angle*? And why does it say “any inscribed angle”?

Problem 74 For one possible line of reasoning, consider this series of pictures, designed to be read from left to right.

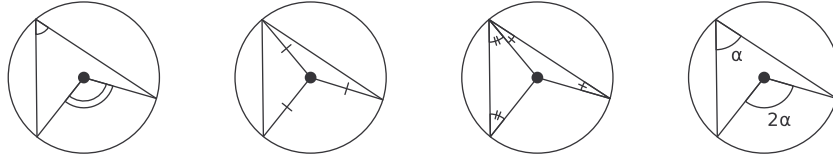

Explain how these pictures “prove” the above theorem. In the process of your explanation, you may need to label parts of the pictures and do some algebra.

Corollary 1. Given an arc of a circle, all inscribed angles intercepting this arc are congruent.

Problem 75 Firstly—what the heck is a corollary? Secondly—what is it saying? Thirdly—why is it true?

Problem 76 Not all inscribed angles look like those in the previous picture. Consider the following pictures:

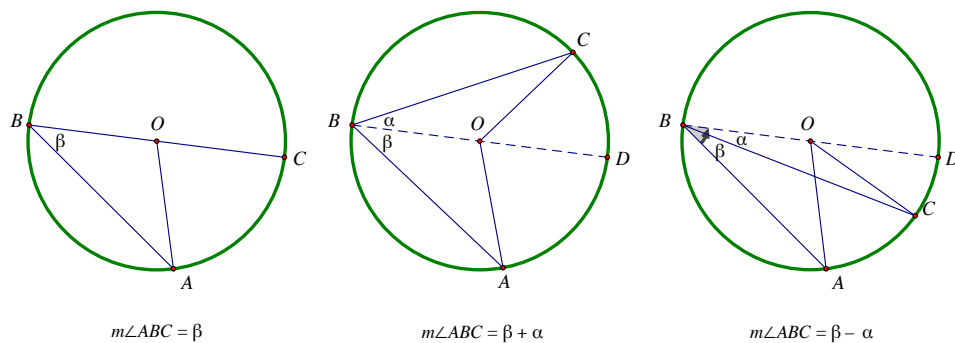

- (a) In each of the pictures, find and explain the relationship between $m\angle ABC$ and $m\angle AOC$.
- (b) Explain why any inscribed angle must fit one of these three cases.

17 More Circles

We think about circles that have certain relations to other shapes.

Problem 77 Prove: The radius of a circle is perpendicular to the tangent where the radius intersects the circle. Hint: Suppose not.

Problem 78 Suppose an angle circumscribes a circle, as shown below. Find a relationship between the measure of the angle and the measure of the central angle intercepted by the same chord.

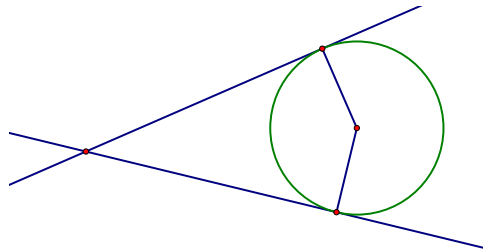

Problem 79 *Show that, given any three non-collinear points in the Euclidean plane, there is a unique circle passing through the three points.*

Problem 80 *Draw four points in the Euclidean plane, no three of which are collinear, that cannot lie on a single circle. Explain your reasoning.*

Problem 81 Using a compass, draw a large circle, and inscribe a quadrilateral in the circle. Measure the four angles. Repeat with another circle and quadrilateral. What do you notice? Identify a condition on any quadrilateral that is inscribed in a circle. Now prove it.

Problem 82 Construct a tangent line to a circle from a point outside the given circle.

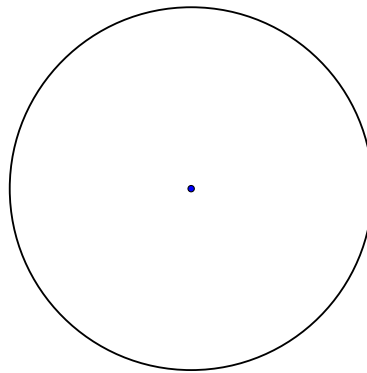

Problem 83 Give an informal derivation of the relationship between the circumference and area of a circle. Imagine cutting a circle into “pie pieces” and rearranging the pieces into a shape like the one below. As the circle is cut into more and more equal-sized “pie pieces,” what does the rearranged shape begin to resemble? Can you find the area of this shape?

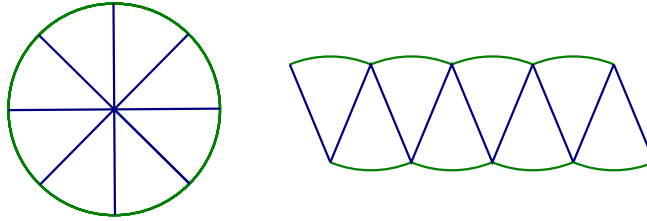

Problem 84 *Derive a formula for the length of the arc intercepted by a central angle of a circle.*



Problem 85 *Derive a formula for the area of a sector of a circle.*



18 Quadrilateral Diagonals

We explore basic shapes.

Imagine you are working at a kite factory and you have been asked to design a new kite. The kite will be a quadrilateral made of synthetic cloth, and it will be formed by two intersecting rods that serve as the diagonals of the quadrilateral and provide structure for the kite.

Problem 86 *To get started, review the definitions of all special quadrilaterals. Be sure to include kite on your list.*

Problem 87 *To consider the possible kite shapes, your task is to describe how conditions on the diagonals determine the quadrilateral. Use fettuccine to model the intersecting rods, and use paper and pencil to draw the rod configurations and resulting kite shapes.*

Here are some hints:

- *Explore diagonals of various lengths, of the same length, and of different lengths.*
 - *Explore various places at which to attach the diagonals to each other, including at one or both of their midpoints.*
 - *Explore various angles that the diagonals might make with each other at their intersection, including the possibility of being perpendicular.*
 - *Indicate what kinds of rotational or reflection symmetry you see in the resulting figure.*
-

Problem 88 *Summarize your findings in a table organized like the following.*

| Quadrilateral | Definition (A quad. with ...) | Diagonals | | | Comments (e.g., symmetry) |
|-----------------|----------------------------------|-----------|--------|-------|------------------------------|
| | | Cong. | Bisect | Perp. | |
| Square | | | | | |
| Rectangle | | | | | |
| Rhombus | | | | | |
| Parallelogram | | | | | |
| Kite | | | | | |
| Trapezoid | | | | | |
| Isosceles Trap. | | | | | |

Part III

Congruence and Similarity

19 Congruence via Transformations

We think about geometric transformations.

Informally, a *transformation* of the plane is a “motion,” such as a rotation or a stretch of the plane, that takes a figure to an *image* of that figure. This activity explores the basic rigid motions: translations (slides), rotations (turns), and reflections (flips).

Problem 89 One of the pairs of figures below shows a translation, and the other pair does not. To identify which is which, draw segments between each point and its image. Use those segments to explain your reasoning.

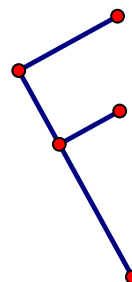
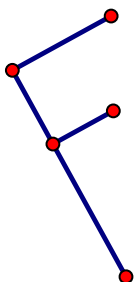
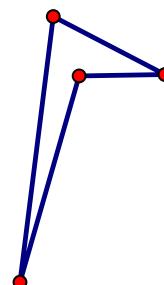
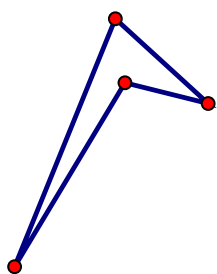

Problem 90 One of the pairs of figures shows a reflection about the given line, and the other pair does not.

- Identify which pair of figures shows a reflection about the given line, and explain how you know.
- Find the line of reflection for the other pair of figures, and explain your reasoning.

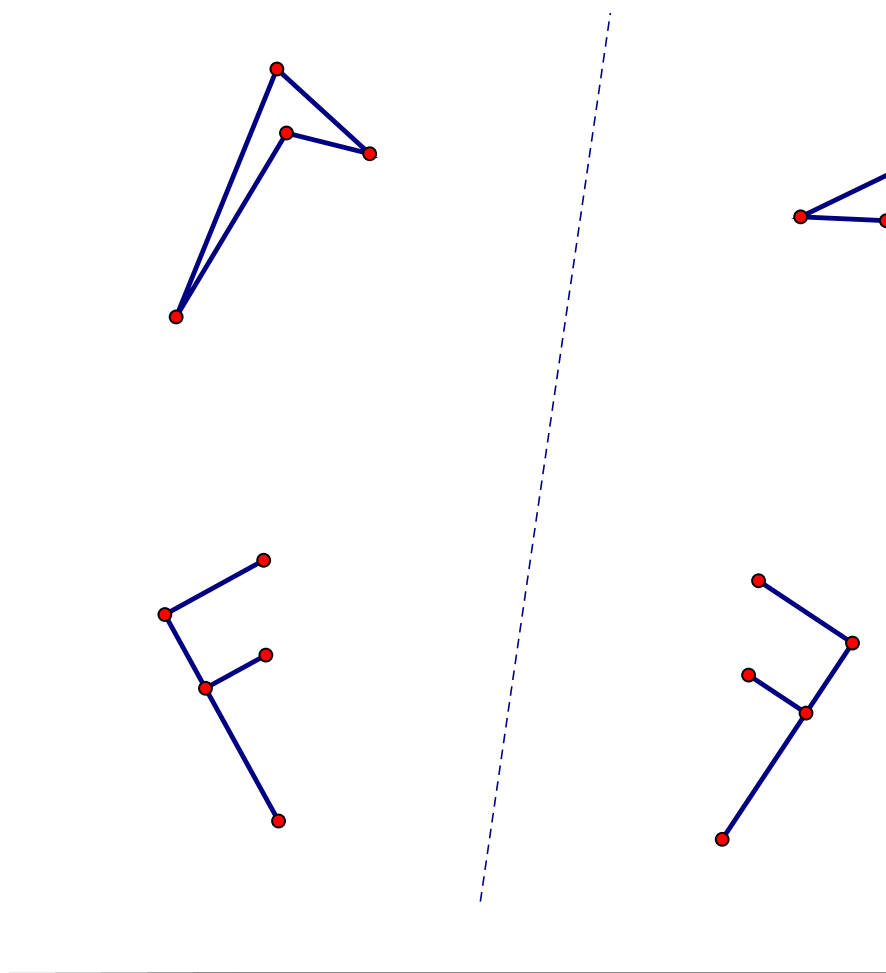

Problem 91 One of the pairs of figures below shows a rotation about point C , and the other pair does not.

- Identify which pair of figures shows a rotation about C , and explain how you know.
- Find the angle of rotation.
- Find the center of and angle of rotation for the other pair of figures. Explain your reasoning.

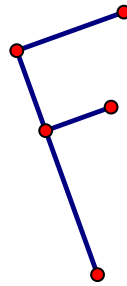
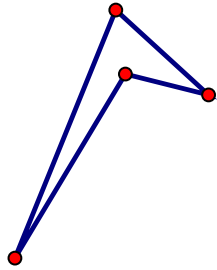

C

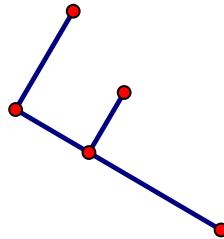
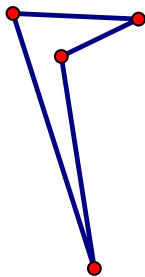

Problem 92 Two figures are said to be congruent if there is a sequence of basic rigid motions that take one figure onto the other.

- (a) Specify a sequence of two or three basic rigid motions that takes one F onto the other. Illustrate intermediate images. Explain your reasoning.

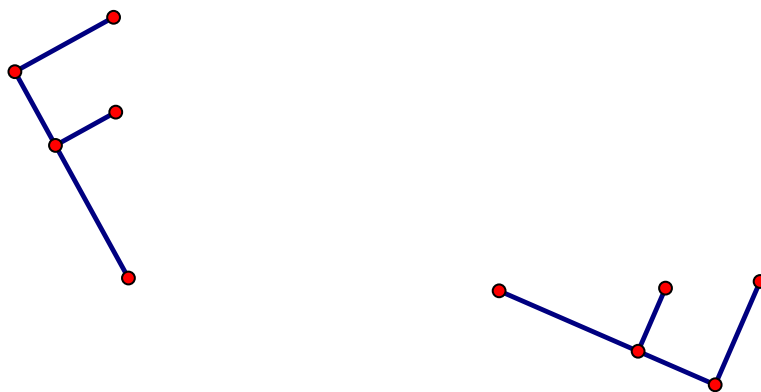

- (b) Explain briefly why, for this pair of figures, sequences of the following types cannot work:

- a rotation followed by a rotation
- a translation followed by a translation
- a reflection followed by a reflection

20 More Transformations

We think about geometric transformations.

Transformations of the plane are considered to be functions that take points as inputs and produce points as outputs. Given a point as input, the corresponding output value is often called the *image* of the point under the transformation. •

Problem 93 *Based on your experience with the basic rigid motions, write definitions of translation, rotation, and reflection. • For each definition, be sure to indicate (1) what it takes to specify the transformation, and (2) how to produce the image of a given point.*

(a) *Translation:*

(b) *Rotation:*

(c) *Reflection:*

• CCSS G-CO.2. Represent transformations in the plane using, e.g., transparencies and geometry software; describe transformations as functions that take points in the plane as inputs and give other points as outputs. Compare transformations that preserve distance and angle to those that do not (e.g., translation versus horizontal stretch).

• CCSS G-CO.4. Develop definitions of rotations, reflections, and translations in terms of angles, circles, perpendicular lines, parallel lines, and line segments.

Problem 94 *Now explore sequences of basic rigid motions. Here are some suggestions to support your explorations:*

- *Use a non-symmetric figure (such as an F).*
- *Use one sheet of tracing paper as the original plane, and use a second sheet of paper to carry out the sequence of transformations.*
- *Trace intermediate figures on both sheets of paper, to keep track of the work.*
- *For reflections, trace the line of reflection on both sheets.*
- *For rotations, use a protractor to help you keep track of angles.*
- *Consider special cases, such as reflections about the same line or rotations about the same point.*
- *Try to predict the result before you actually carry out the sequence of transformations.*

Author(s): Bart Snapp and Brad Findell

Describe briefly what you can say about each of the following sequences of basic rigid motions. Include special cases in your descriptions.

(a) *Translation followed by translation*

(b) *Rotation followed by rotation*

(c) *Reflection followed by reflection*

(d) *Translation followed by rotation*

(e) *Translation followed by reflection*

(f) *Rotation followed by reflection*

21 Symmetries

We introduce symmetries.

Definition 4. A symmetry is a transformation that takes a figure onto itself.

Problem 95 List the symmetries of an equilateral triangle. Explain how you know you have them all.

Problem 96 Flip through these notes and describe the symmetries you notice. Try to find reflection symmetry, rotation symmetry, and translation symmetry.

Problem 97 Suppose the symmetries of a square are called R_0 , R_{90} , R_{180} , R_{270} , V , H , D , D' , based upon the figure below.

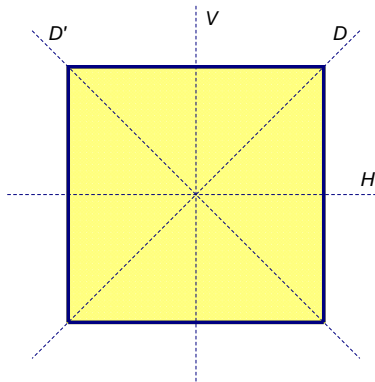

Hint: To identify a single transformation that accomplishes a sequence of transformations, do the transformations physically with a square piece of paper marked with "FRONT" on the side that starts facing you. Or mark the corners of the square with A , B , C , and D .

Author(s): Bart Snapp and Brad Findell

- (a) Complete the following table, where the entry at (row, column) is the symmetry that results from the sequence of symmetries given by the row heading followed by the column heading.
- (b) What patterns and not-quite-patterns do you notice in the table? For example, which elements “commute” with which other elements?
- (c) What facts about isometries can you observe in the table? For example, what can you say generally about sequences of rotations and reflections?

| | R_0 | R_{90} | R_{180} | R_{270} | V | H | D | D' |
|-----------|-------|----------|-----------|-----------|-----|-----|-----|------|
| R_0 | | | | | | | | |
| R_{90} | | | | | | | | |
| R_{180} | | | | | | | | |
| R_{270} | | | | | | | | |
| V | | | | | | | | |
| H | | | | | | | | |
| D | | | | | | | | |
| D' | | | | | | | | |

22 Congruence Criteria

We develop triangle congruence from basic rigid motions.

In this activity, we show how the common triangle congruence criteria follow from what we now know about rigid motions. Recall that two figures are said to be *congruent* if there exists a basic rigid motion (translation, rotation, or reflection) or a sequence of basic rigid motions that maps one figure onto the other.

• CCSS G-CO.8. Explain how the criteria for triangle congruence (ASA, SAS, and SSS) follow from the definition of congruence in terms of rigid motions.

Problem 98 *Proof of Side-Angle-Side (SAS) congruence.* Suppose $\triangle ABC$ and $\triangle XYZ$ are such that $AB = XY$, $AC = XZ$, and $\angle A \cong \angle X$. Prove, using basic rigid motions, that $\triangle ABC \cong \triangle XYZ$. Consider the figure below.

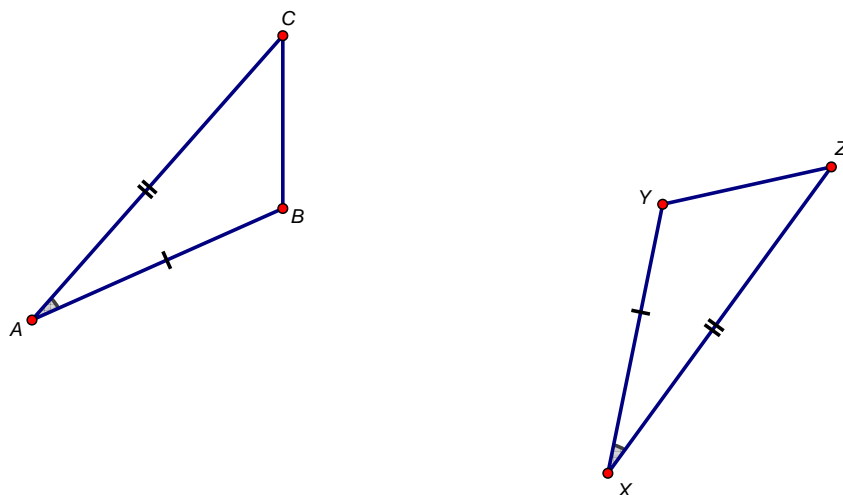

Fill in the details of the following proof.

- (a) Translate $\triangle ABC$ through the vector \overrightarrow{AX} . Call the image $\triangle A'B'C'$. Explain why A' and X coincide.

- (b) Rotate $\triangle A'B'C'$ about $X = A'$ through $\angle B'XY$ so that ray $\overrightarrow{A'B'}$ is along ray \overrightarrow{XY} . Call the image $\triangle A''B''C''$. Explain how you know the segments $\overline{A''B''}$ and \overline{XY} coincide.
- (c) Reflect $\triangle A''B''C''$ about the line $\overleftrightarrow{A''B''} = \overleftrightarrow{XY}$. Call the image $\triangle A'''B'''C'''$. Explain why $\overline{A'''C'''}$ and \overline{XZ} coincide.
- (d) Explain how you now know that all sides and angles of $\triangle A'''B'''C'''$ are congruent to the corresponding sides and angles of $\triangle XYZ$.
- (e) Explain how to modify the above steps to handle the following different cases:
- Initially $X = A$.
 - After the translation, $\overline{A'B'}$ and \overline{XY} coincide.
 - After the rotation, $\overline{A''C''}$ and \overline{XZ} coincide. (Hint: Consider whether C'' and Z are on the same side or on opposite sides of \overleftrightarrow{XZ} .)

Problem 99 *Proof of Angle-Side-Angle (ASA) congruence.* Suppose $\triangle ABC$ and $\triangle XYZ$ are such that $AB = XY$, $\angle A \cong \angle X$, and $\angle B \cong \angle Y$. Prove, using basic rigid motions, that $\triangle ABC \cong \triangle XYZ$.

- (a) Outline a general proof for the figure below.

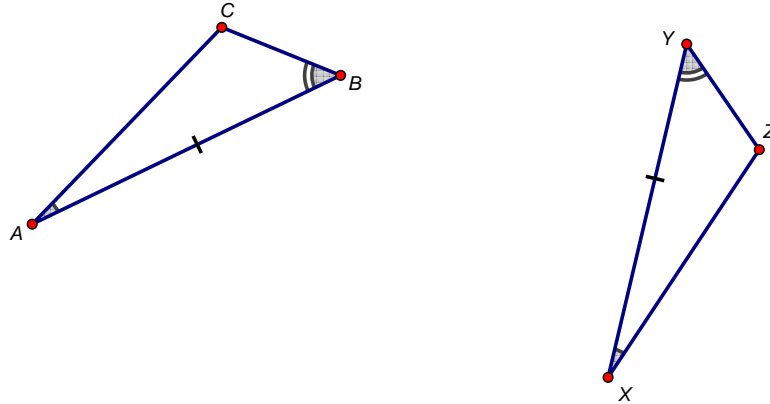

- (b) Explain carefully how you know, after the sequence of rigid motions, that the “final image” of C coincides with Z .
- (c) Describe how to modify the outline to handle other cases.

Problem 100 In a previous activity, you used triangle congruence criteria to prove the following results:

- The Isosceles Triangle Theorem.
- The points on a perpendicular bisector of a segment are exactly those that are equidistant from the endpoints.

Verify that these results could have been established using only SAS and ASA congruence. (Thus, you may use these results in the problems that follow.)

Problem 101 Proof of Hypotenuse-Leg (HL) congruence. Suppose $\triangle ABC$ and $\triangle XYZ$ are such that $\angle C$ and $\angle Z$ are right angles, $AB = XY$, and $BC = YZ$. Prove that $\triangle ABC \cong \triangle XYZ$.

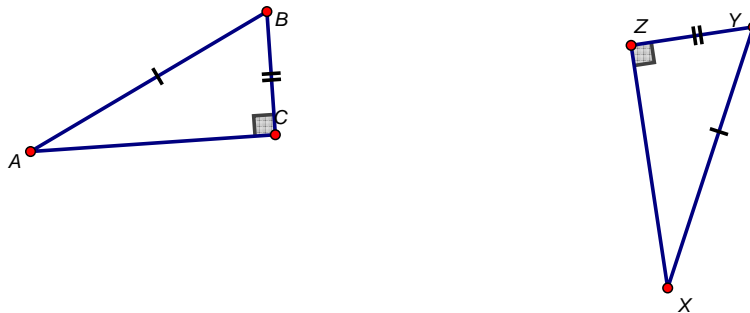

Problem 102 *Proof of Side-Side-Side (SSS) congruence.* Suppose $\triangle ABC$ and $\triangle XYZ$ are such that $AB = XY$, $AC = XZ$, and $BC = YZ$. Prove, using basic rigid motions, that $\triangle ABC \cong \triangle XYZ$. Build toward the general case through the following steps:

- (a) Case 1a: $A = X$, $B = Y$, and C and Z lie on opposite sides of \overleftrightarrow{AB} . (Hint: Explain why the situation must be like one of the figures below, argue that \overleftrightarrow{AB} is the perpendicular bisector of \overline{CZ} , and then use a reflection.)

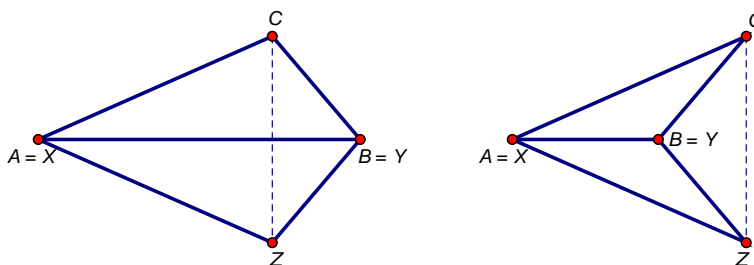

- (b) Case 1b: $A = X$, $B = Y$, and C and Z lie on the same side of $\overleftrightarrow{AB} = \overleftrightarrow{XY}$. (Hint: Consider a reflection of one of the triangles and use the previous case.)
- (c) Case 2: $A = X$ but $B \neq Y$.
- (d) Case 3: The general case.

23 Parallels

We seek to understand the Parallel Postulate and its consequences.

In the following problems, you may assume the following:

Postulate 1 (Parallel Postulate). *Given a line and a point not on the line, there is exactly one line passing through the point which is parallel to the given line.*

You may also use previously-established results, such as the following:

- The measures of adjacent angles add as they should.
- A straight angle measures 180° .
- A 180° rotation about a point on a line takes the line to itself.
- A 180° rotation about a point off a line takes the line to a parallel line.

Now you may get started!

Problem 103 *Prove that vertical angles are congruent. Then try to prove it another way.*

Problem 104 *Prove: If a pair of parallel lines is cut by a transversal, then alternate interior angles are equal and corresponding angles are equal.*

Problem 105 *Prove: If a pair of alternate interior angles or a pair of corresponding angles of a transversal with respect to two lines are equal, then the lines are parallel.*

Problem 106 *The previous two problems seem almost identical to one another. How are they different?*

Problem 107 *Prove: The angle sum of a triangle is 180° .*

24 Midsegments

We prove the midsegment theorem.

Definition 5. *In a triangle, a midsegment is a line joining the midpoints of two sides.*

Theorem 6. *Midsegment Theorem: A midsegment in a triangle is parallel to and half the length of the corresponding side.*

In this activity, we prove the midsegment theorem. First, we need some results about parallelograms.

Problem 108 *Prove the following theorem: If the diagonals of a quadrilateral bisect each other, then the quadrilateral is a parallelogram.*

Problem 109 *Prove the following theorem: If one pair of sides of a quadrilateral are congruent and parallel, then the quadrilateral is a parallelogram.*

Problem 110 Prove the midsegment theorem. (Hint: Extend the midsegment \overline{DE} to a point X such that $EX = DE$, and then find quadrilaterals that must be parallelograms by the previous results.)

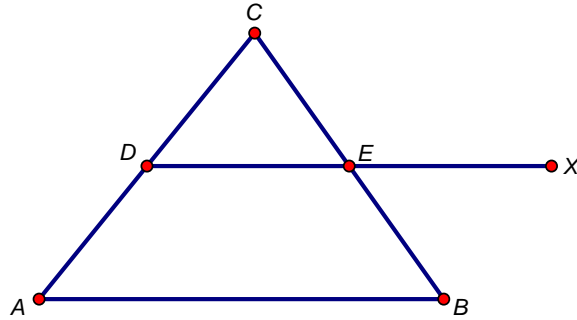

25 Similarities

We introduce similarity.

Problem 111 *Based on your experience with the stretching activity, write a definition of dilation. Be sure to indicate (1) what it takes to specify the transformation, and (2) how to produce the image of a given point.*

Problem 112 *Based on your experience with the stretching activity, describe for a dilation:*

- (a) *What happens to line segments?*
- (b) *What happens to angles?*
- (c) *What happens to lines passing through the center of the dilation?*
- (d) *What happens to lines not passing through the center of the dilation?*

Definition 6. *A geometric figure is similar to another if the second can be obtained from the first by a sequence of rotations, reflections, translations, and dilations.*

Problem 113 *For each of the pairs of objects on the following pages, do the following:*

- (a) *Trace the smaller figure on plastic. Then close one eye and try to hold the plastic between your eye and the paper so that the tracing “exactly” covers the larger figure. Be sure that the plane of the paper and the plane of the plastic are parallel. (Why does this matter?)*

Author(s): Bart Snapp and Brad Findell

- (b) *If the objects are similar, find a sequence of rotations, reflections, translations, and dilations that takes one figure onto the other.*
- (c) *If the objects are similar, try to find a single dilation that demonstrates the similarity. If you cannot find such a dilation, explain how you know you cannot.*

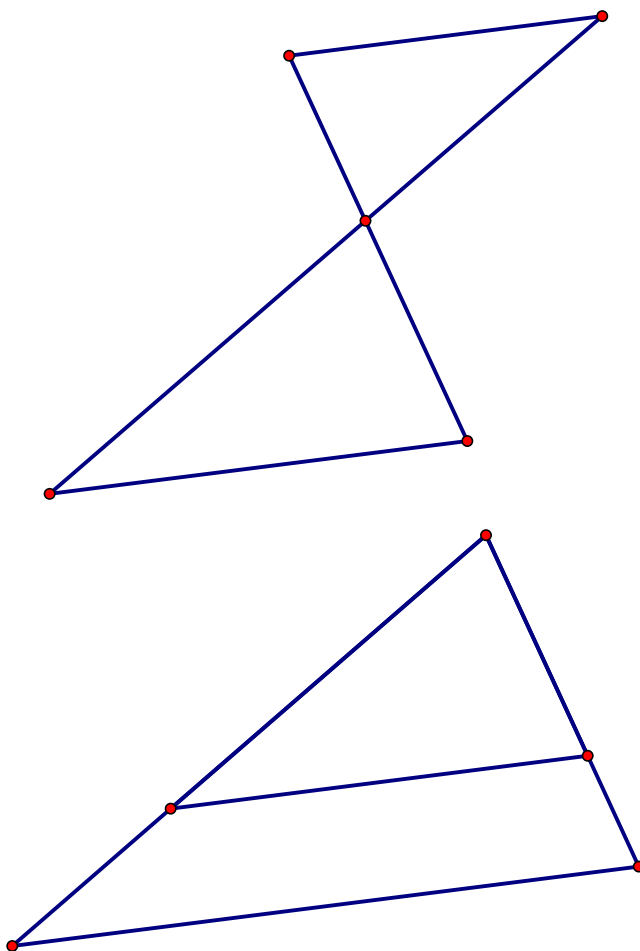

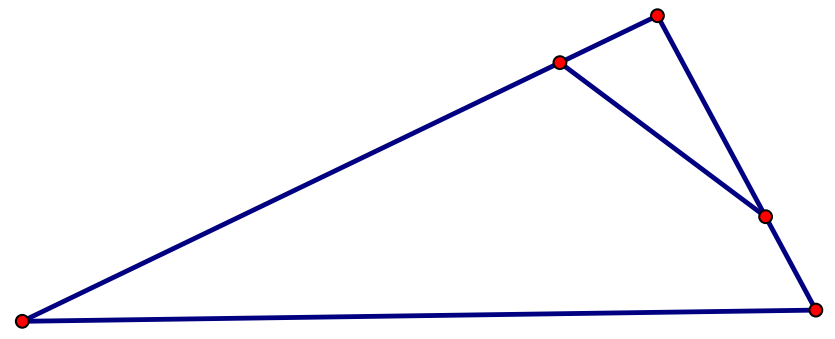
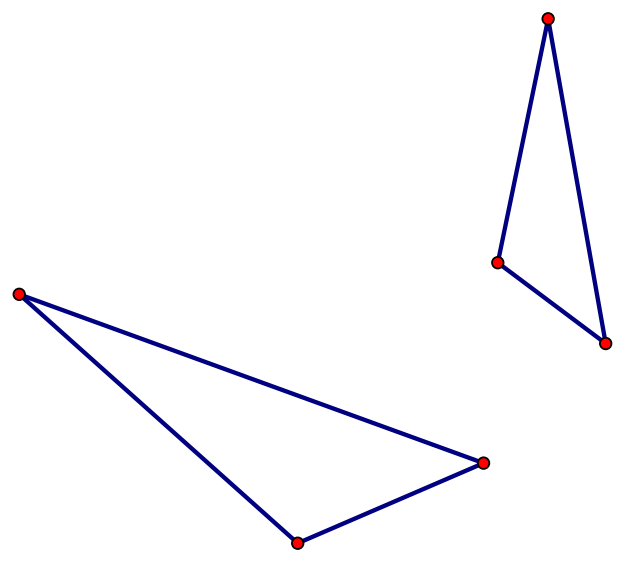

Problem 114 Describe a general (and foolproof) way of demonstrating that any two circles are similar.

• CCSS G-C.1 Prove that all circles are similar.

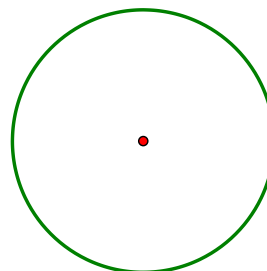
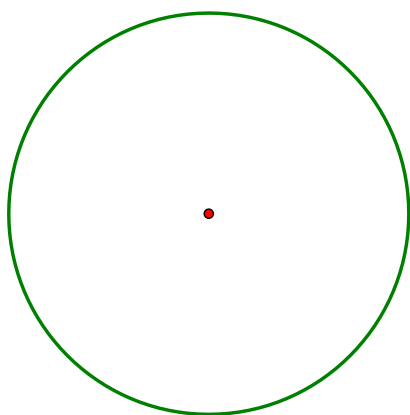

Problem 115 Describe a general (and foolproof) way of demonstrating that any two parabolas are similar.

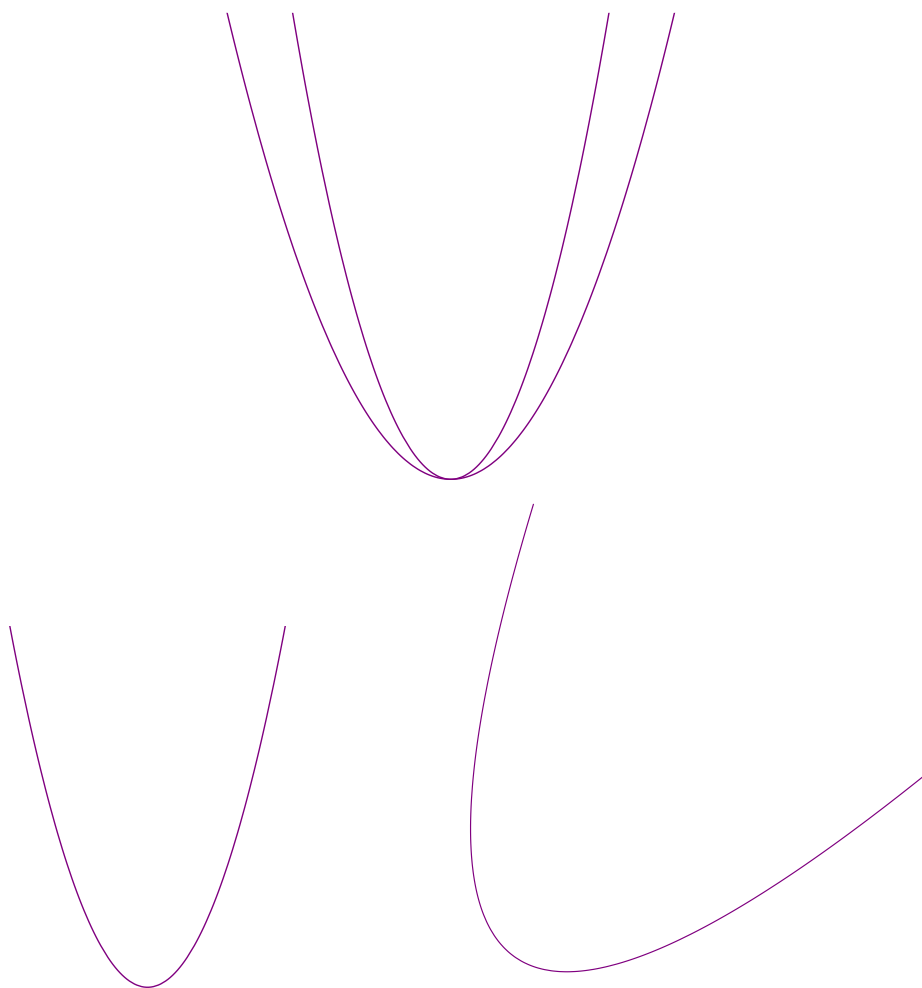

26 Side-Splitter Theorems

We prove fundamental theorems about similar triangles.

In this activity, we will show that the properties of dilations, which you noticed in a previous activity, can be proven *without* using facts about transversals and parallel lines. Instead, we use the area formula for triangles. *Note: For a given base, draw the corresponding altitude to reason about a triangle's area.*

Background: Areas of triangles

Question 116 For the triangle area formula to be valid, what must be true about the base and height measurements?

Problem 117 Suppose the area of $\triangle SPR = 8$ square inches and the area of $\triangle QPR = 5$ square inches.

- Thinking of SR and RQ as bases of these triangles, respectively, what are their heights?
- Then what can you say about $\frac{SR}{RQ}$? What about $\frac{SR}{SQ}$?
- What can you say generally about how these ratios depend upon the areas of the triangles?

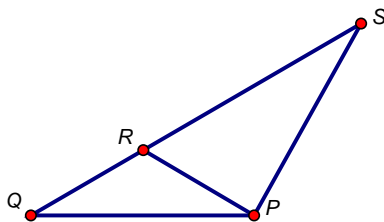

Author(s): Bart Snapp and Brad Findell

Problem 118 For the trapezoid below, explain why the area of $\triangle BAD$ is equal to the area of $\triangle BAC$. Name two other triangles that have the same area.

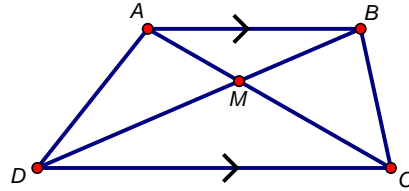

Problem 119 For the parallelogram below, which triangle has the greatest area: $\triangle XYZ$, $\triangle WXY$, $\triangle ZWX$, or $\triangle YZW$? Explain.

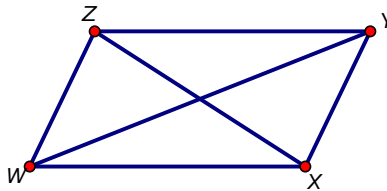

Side Splitting

Problem 120 Prove the **Parallel-Side Theorem**: If a line in a triangle is parallel to a side of a triangle, then it splits the other sides of the triangle proportionally.

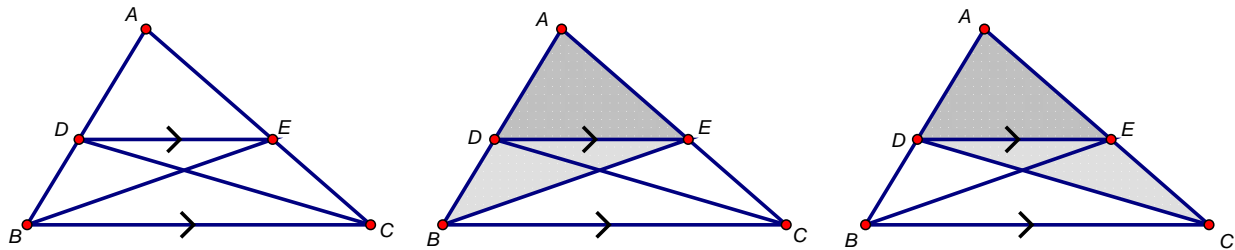

- How do the areas of $\triangle ADE$ and $\triangle DBE$ relate to AD and DB ? Explain.
- How do the areas of $\triangle ADE$ and $\triangle ECD$ relate to AE and EC ? Explain.
- How do the areas of $\triangle DBE$ and $\triangle ECD$ compare? Explain.
- Use the previous results to show that $\frac{DB}{AD} = \frac{EC}{AE}$.
- What the heck did we just do? What does this say?
- Where in the proof did we use the fact that $\overline{DE} \parallel \overline{BC}$?

Problem 121 Use some algebra to show, in the previous picture, that $\frac{AB}{AD} = \frac{AC}{AE}$.

Problem 122 Prove: Next we prove, in the previous figure, that $\frac{BC}{DE} = \frac{AB}{AD} = \frac{AC}{AE}$. Here are the steps.

- How do we know that $\angle ADE \cong \angle ABC$?
- Translate $\triangle ADE$ by the vector \overrightarrow{DB} so that the image $\angle A'D'E'$ of $\angle ADE$ coincides with $\angle ABC$. Draw a picture of the result.
- What segments are parallel now? How do you know?
- Now explain why $\frac{BC}{DE} = \frac{AB}{AD} = \frac{AC}{AE}$ is equal to a common ratio from the previous problem.

Problem 123 Explain briefly how the Parallel-Side Theorem implies the AA criterion for triangle similarity. (Hint: Be sure to use the definition of similarity in terms of basic rigid motions and dilations.)

Problem 124 The **Split-Side Theorem** is the converse of the Parallel-Side Theorem.

- (a) State the Split-Side Theorem.
- (b) Prove the Split-Side Theorem. (Hint: Using the previous figures, draw a line through D and parallel to \overline{BC} , and let X be the point where the new line intersects \overline{AC} . By the previous results, \overline{DX} divides the sides proportionally. Then argue that E and X must be the same point.)

Problem 125 Use the Split-Side Theorem to justify the following properties of a dilation given by a center and a scale factor:

- (a) A dilation takes a line not passing through the center of the dilation to a parallel line, and leaves a line passing through the center unchanged.
- (b) The dilation of a line segment is longer or shorter in the ratio given by the scale factor.

Problem 126 Explain briefly how the Split-Side Theorem establishes the SAS criterion for triangle similarity.

27 Trigonometry Checkup

We review trigonometry.

This activity is intended to remind you of key ideas from high school trigonometry.

Problem 127 *What are the ratios of side lengths in a 45° - 45° - 90° triangle? Explain where the ratios come from, including why they work for any such triangle, no matter what size. (Hint: Use the Pythagorean Theorem.)*

Problem 128 *What are the ratios of side lengths in a 30° - 60° - 90° triangle? Explain where those the come from. (Hint: How might an equilateral triangle help.)*

Problem 129 Consider the right triangle below with an angle of α , sides of length x and y , and hypotenuse of length r , as labeled.

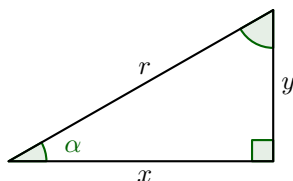

- (a) If we imagine angle α is fixed, why are ratios of pairs of side lengths the same, no matter the size of the triangle?•

• CCSS G-SRT.6. Understand that by similarity, side ratios in right triangles are properties of the angles in the triangle, leading to definitions of trigonometric ratios for acute angles.

- (b) Using the triangle above (and your memory of Precalculus), write down the side-length ratios for sine, cosine, and tangent:

$$\sin \alpha =$$

$$\cos \alpha =$$

$$\tan \alpha =$$

- (c) What values of α make sense in right triangle trigonometry? (We overcome these bounds later in circular trigonometry.)

- (d) What does it mean to say that these ratios depend upon the angle α ?

- (e) Why is only one of the triangle's three angles necessary in defining these ratios?

Problem 130 Use your work so far to find the following trigonometric ratios:

(a) $\sin 30^\circ =$ $\cos 30^\circ =$ $\tan 30^\circ =$

(b) $\sin 45^\circ =$ $\cos 45^\circ =$ $\tan 45^\circ =$

(c) $\sin 60^\circ =$ $\cos 60^\circ =$ $\tan 60^\circ =$

(d) $\sin 0^\circ =$ $\cos 0^\circ =$ $\tan 0^\circ =$

Problem 131 You may recall the identity $\sin^2 \vartheta + \cos^2 \vartheta = 1$.

(a) Explain why the equation is true.

(b) Why is it called an identity?

(c) Why is it called a Pythagorean identity?

• CCSS F-TF.8. Prove the Pythagorean identity $\sin^2(\vartheta) + \cos^2(\vartheta) = 1$ and use it to find $\sin(\vartheta)$, $\cos(\vartheta)$, or $\tan(\vartheta)$ given $\sin(\vartheta)$, $\cos(\vartheta)$, or $\tan(\vartheta)$ and the quadrant of the angle.

Problem 132 In right triangle trigonometry, there are indeed two acute angles, as shown in the figure below. •

• CCSS G-SRT.7. Explain and use the relationship between the sine and cosine of complementary angles.

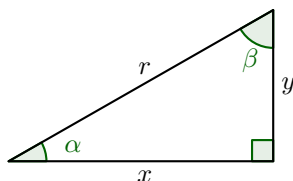

(a) How are the angles α and β related? Explain why.

(b) Using lengths in the above triangle, find the following ratios:

$$\sin \alpha = \quad \quad \quad \cos \alpha =$$

$$\sin \beta = \quad \quad \quad \cos \beta =$$

(c) What do you notice about the sine and cosine of complementary angles?

(d) Explain why the result makes sense.

Given an angle and a side length of a right triangle, you can find the missing side lengths. • This is called “solving the right triangle.” And given the sine, cosine, or tangent of an angle, you can find the other two ratios. (Hint: In either case, draw a triangle.)

• CCSS G-SRT.8. Use trigonometric ratios and the Pythagorean Theorem to solve right triangles in applied problems.

Problem 133 Suppose $\sin \alpha = \frac{3}{5}$. Then $\cos \alpha =$, $\tan \alpha =$.

28 Please be Rational

We prove that the square root of two is not rational.

Let's see if we can give yet another proof that the square root of two is not rational. Consider the following isosceles right triangle:

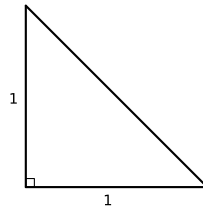

Problem 134 *Using the most famous theorem of all, how long is the unmarked side?*

Problem 135 *Suppose that the unmarked side has a rational length. In that case how could we express it?*

Problem 136 *Explain why there would then be a smallest isosceles right triangle with integer sides. Considering the problem above, how long would the sides be? Draw and label a picture.*

Problem 137 Now fold your smallest isosceles right triangle with integer sides along the dotted line like so:

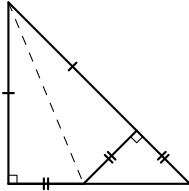

Describe how to accomplish the fold, and explain why the figure is as marked.

Problem 138 Explain how we have now found an isosceles right triangle with integer sides that is now smaller than the smallest isosceles right triangle with integer sides. Is this possible? What must we now conclude?

29 Rep-Tiles

We study self-similar shapes called rep-tiles.

A **rep-tile** is a polygon where several copies of a given rep-tile fit together to make a larger, similar, version of itself. If 2 copies are used, we call it a *rep-2-tile*, if 3 copies are used, we call it a *rep-3-tile*, and if n copies are used, we call it a *rep- n -tile*. Below is an example of a rectangle that is a rep-4-tile.

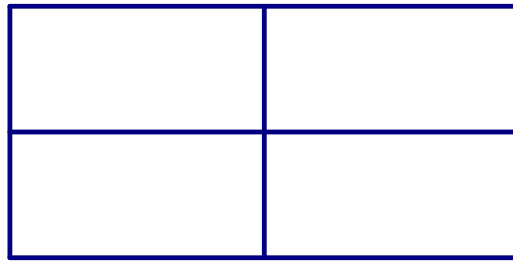

Problem 139 Explain why every parallelogram is a rep-4-tile. Give an example, and compare the perimeter and area of the larger figure to that of the original.

Problem 140 Explain why every triangle is a rep-4-tile. Give an example, and compare the perimeter and area of the larger figure to that of the original.

Problem 141 Explain why every parallelogram and every triangle is a rep-9-tile. Give an example of each, and compare the perimeter and area of the larger triangle to that of the original. Can you generalize your result? In other words, for what values of n can you say that every parallelogram and every triangle is a rep- n -tile?

Problem 142 With a separate sheet of paper, draw and cut out:

- (a) An isosceles right triangle whose sides have lengths $1''$, $1''$, and $\sqrt{2}''$.
- (b) A rectangle whose sides have lengths $1''$ and $\sqrt{2}''$.

Working with a partner, show that each of these polygons is a rep-2-tile. And in each case, how do the perimeter and area of the larger polygon compare to the perimeter and area of the original?

Problem 143 With a fresh sheet of paper, start a table to summarize your work so far. Use **exact** answers whenever possible.

| rep-tile | scale factor (new:old) | perimeter (new:old) | area (new:old) |
|--------------------|------------------------|---------------------|----------------|
| <i>description</i> | | | |
| \vdots | \vdots | \vdots | \vdots |

Problem 144 *Geometry Giorgio suggests that a rectangle whose sides have lengths 1'' and 4'' is also a rep-2-tile. Is he right? If you should happen to search the Internet for other examples of rep-2-tiles, you might find a surprise.*

Problem 145 *With a separate sheet of paper, draw and cut-out:*

- (a) *A 30-60-90 right triangle whose shortest side has length 1''.*
- (b) *A rectangle whose sides have lengths 1'' and $\sqrt{3}$ ''.*

Working with a partner, show that each of these polygons is a rep-3-tile.

Problem 146 *For each rep-tile above, compute the perimeter and area. In each case, how does this relate to the perimeter and area of the larger polygon? Add this information to your table.*

30 Rep-Tiles Repeated

We further our study of rep-tiles.

Problem 147 With a separate sheet of graph paper, draw and cut out the following polygons:

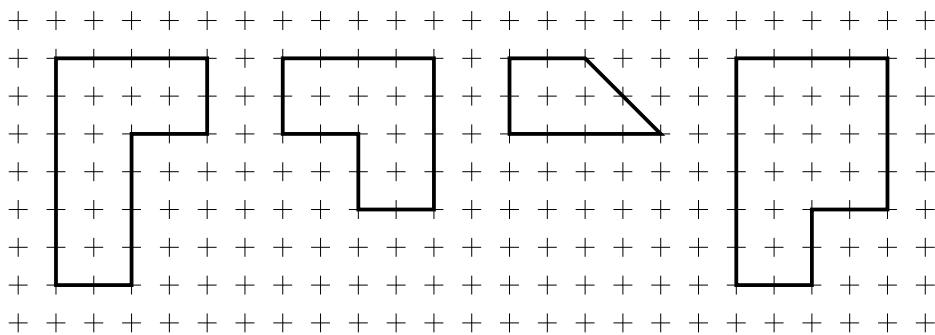

Working with a partner, show that each of these polygons is a rep-4-tile.

Problem 148 For each rep-tile above, compute the perimeter and area. In each case, how does this relate to the perimeter and area of the larger polygon?

Problem 149 With a separate sheet of paper, trace and cut out the following polygons:

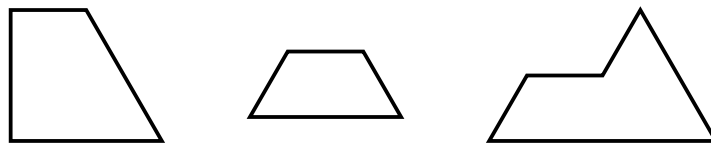

Working with a partner, show that each of these polygons is a rep-4-tile.

Author(s): Bart Snapp and Brad Findell

Problem 150 Explain why every rectangle whose sides have ratio $1 : \sqrt{n}$ is a rep- n -tile.

Problem 151 Explain how you know that any polygonal rep-tile will tessellate the plane.

Problem 152 Give an example of a polygon that tessellates the plane that is not a rep-tile.

Problem 153 Every tessellation made by rep-tiles will have **symmetry of scale**. What does it mean to have *symmetry of scale*?

Problem 154 Consider the tessellations made by rep-tiles you've seen so far. What other symmetries do they have?

Problem 155 Do you think you can have a tessellation that has symmetry of scale but no other symmetries?

31 Scaling Area

We investigate how area changes when an object is scaled.

Problem 156 *Is a 3×5 rectangle similar to a 4×6 rectangle? Explain your reasoning. Now come up with another explanation.*

Problem 157 *Use area formulas to explain what happens to the area of a rectangle under scaling by a factor of k ? What about a triangle? What about a circle?*

Problem 158 Below is a figure and a dilation of that figure about point O .

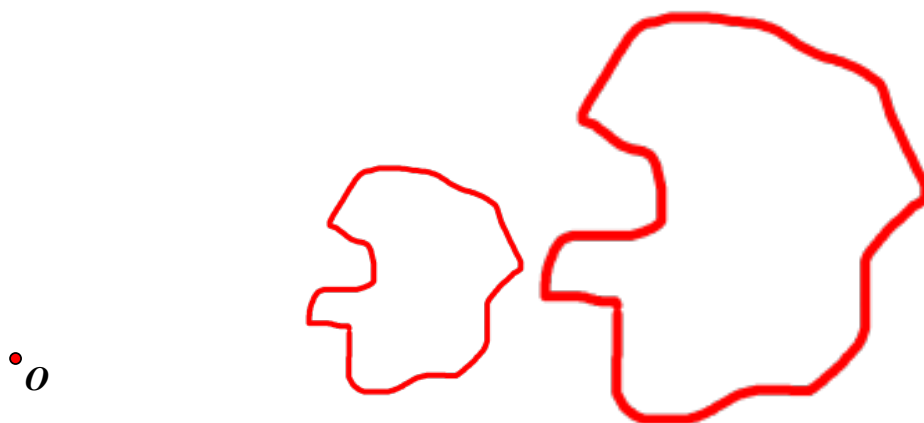

- Find the scale factor of the dilation. Explain your reasoning.
- What can you say about the areas of the two figures? Explain your reasoning.

32 Turn Up the Volume!

We investigate areas and volumes.

In this activity, we will investigate formulas for area and volume.

Problem 159 Explain how the following picture “proves” that the area of a right triangle is one half of the base times the height.

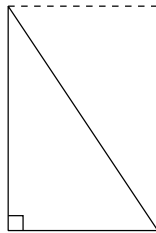

Problem 160 “Shearing” is a process where you take a shape, cut it into thin parallel strips, and then move the strips in a direction parallel to the strips to make a new shape. By Cavalieri’s principle:

Shearing parallel to a fixed direction does not change the n -dimensional measure of an object.

What is this saying?

Problem 161 Building on the first two problems, explain how the following picture “proves” that the area of any triangle is one half of the base times the height.

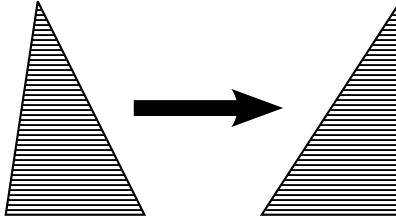

Problem 162 Explain how to use a picture to “prove” that a triangle of a given area could have an arbitrarily large perimeter.

Problem 163 *Shearing is a special case of Cavalieri's principle, which, in two dimensions, is stated as follows:*

Suppose two regions in a plane are contained between two parallel lines. If every line parallel to the given lines intersects the two regions in equal lengths, then the regions have equal area.

Give an intuitive argument explaining why Cavalieri's principle is true.

Problem 164 *State Cavalieri's principle in three dimensions.*

Problem 165 *Cut out the provided net. Then fold it and tape it to create a square-based pyramid. With your neighbors, show that three such square-based pyramids can form a cube.*

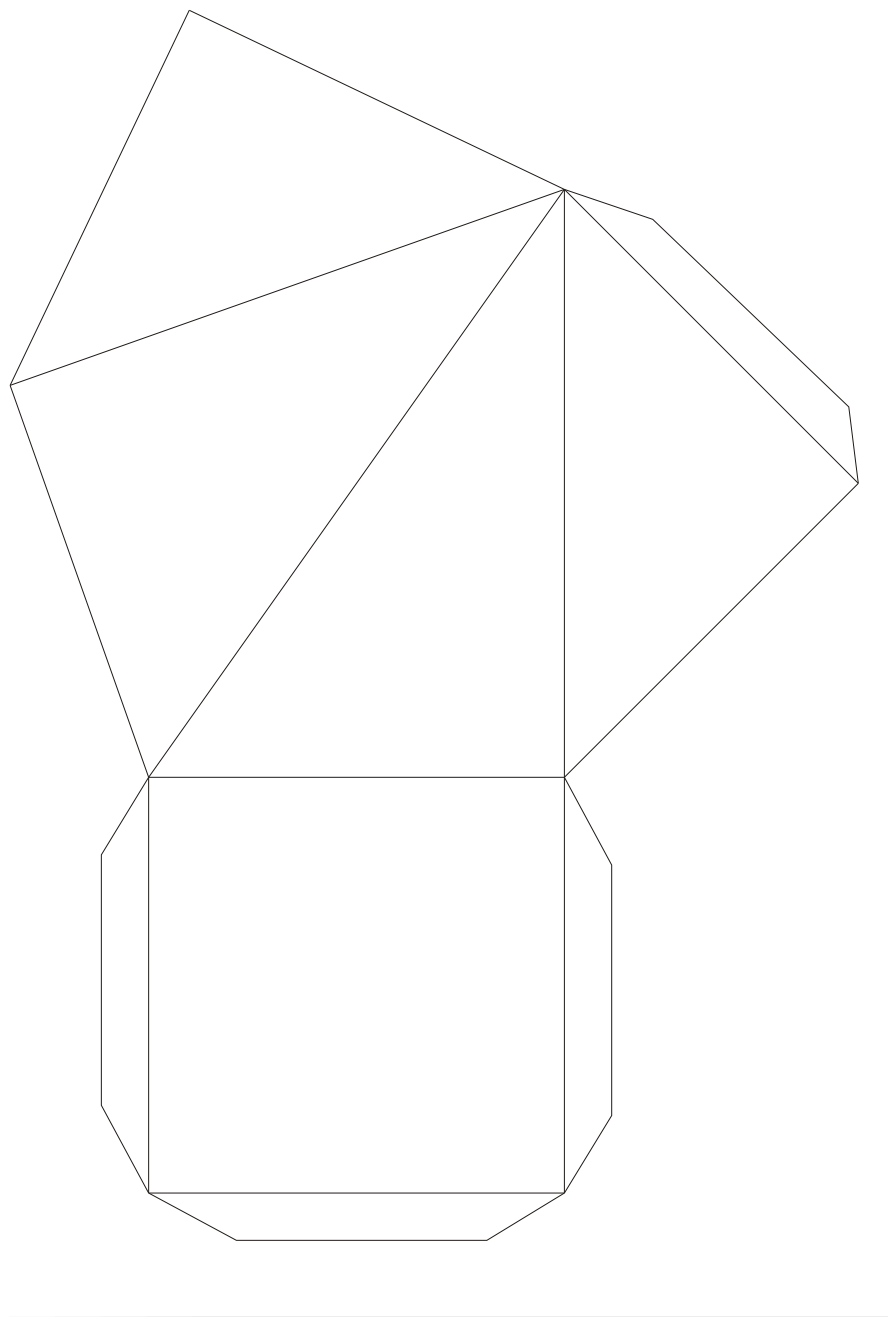

Problem 166 Use your work above to derive a formula for the volume of a right pyramid with a square base. The formula should be in terms of the side length of the square base.

Problem 167 Use Cavalieri's principle to explain the formula for **every** pyramid with an $s \times s$ square base of height s in terms of s . Be sure to describe how this formula is different from the previous one.

Problem 168 Provide an informal explanation of a volume formula for any pyramid-like object with a base of area B and height h . Be sure to describe what you mean by "pyramid-like" and whether your formula works for a cone.

Problem 169 In this problem you derive the formula for the volume of a sphere of radius r . The figures below shows a half-sphere of radius r alongside a cylinder of radius r and height r with a cone of radius r and height r removed.

• CCSS G-GME.2. Give an informal argument using Cavalieri's principle for the formulas for the volume of a sphere and other solid figures.

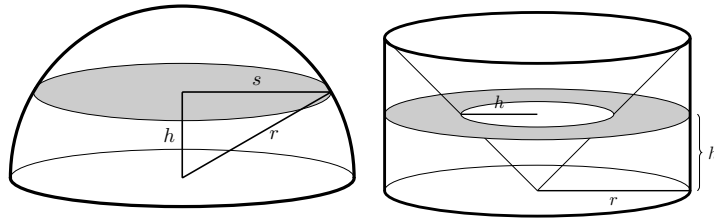

Think of r as fixed, and think of h as the varying height of a cross section. The (hard to read) s is the radius of the cross section of the sphere.

- The heights of the cylinder and the cone are not h . What are their heights?
- What is h ? Explain why the several values labeled h are indeed equal.
- Draw and label an “aerial view” of the cross sections.
- Explain why the cross sections at height h have the same area.
- Use the formula for the volume of a cone and Cavalieri's principle to derive a formula for the volume of a sphere of radius r .

Part IV

Coordinates

33 Coordinate Constructions

We use Cartesian coordinates to help us understand geometry.

In synthetic geometry, point, line and plane are taken to be undefined terms. In analytic (coordinate) geometry, in contrast, we make the following definitions.

Definition 7. A point is an ordered pair (x, y) of real numbers. A line is the set of ordered pairs (x, y) that satisfy an equation of the form $ax + by = c$, where a , b , and c are real numbers and a and b are not both 0.

Many of the problems below are expressed generally. You may find it useful to try some specific examples before the general case.

Problem 170 In the above definition of a line in coordinate geometry, why is it important to require that a and b are not both 0?

Problem 171 Given points (x_1, y_1) and (x_2, y_2) , find the distance between them in the coordinate plane.

Problem 172 Find the midpoint of the segment from (x_1, y_1) and (x_2, y_2) . Explain why your formula makes sense.

Problem 173 Recall that in synthetic geometry, a circle is defined as the set of points that are equidistant from a center. Use this definition to determine the equation of circle with center (h, k) and radius r .

• CCSS G-GPE.1. Derive the equation of a circle of given center and radius using the Pythagorean Theorem; complete the square to find the center and radius of a circle given by an equation.

Problem 174 For each pair of points below, find an equation of the line containing the two points.

- (a) Points $(2, 3)$ and $(5, 7)$.
- (b) Points $(2, 3)$ and $(2, 7)$.
- (c) Points $(2, 3)$ and $(5, 3)$.
- (d) Points (x_1, y_1) and (x_2, y_2) .

Problem 175 Express each of your previous equations in the form $ax+by=c$ and also in the form $y=mx+b$. What are the advantages and disadvantages of these forms?

Problem 176 In school mathematics, lines are usually of the form $y=mx+b$. Why is it unambiguous to talk about the slope of such a line? In other words, given a non-vertical line in the plane, explain why any two points on the line will yield the same slope. •

• CCSS 8.EE.6. Use similar triangles to explain why the slope m is the same between any two distinct points on a non-vertical line in the coordinate plane; derive the equation $y=mx$ for a line through the origin and the equation $y=mx+b$ for a line intercepting the vertical axis at b .

34 Bola, Para Bola

We seek to deepen our understanding of parabolas.

We've mentioned several times that a parabola is the set of points that are equidistant from a given point (the focus) and a given line (the directrix):

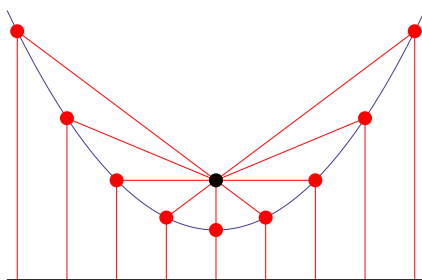

In this activity we are going to reconcile the definition given above with the equation that you know and love (admit it!):

$$y = ax^2 + bx + c$$

Problem 177 *How do we compute the distance between two points? Be explicit!*

Problem 178 *Let's see if we can derive the formula for a parabola with its focus at $(0, 1)$ and its directrix being the line $y = 0$.*

- (a) *Graph the focus and the directrix, sketch what the parabola might look like, and identify a generic point (x, y) .*

- (b) Draw on the graph the distance from (x, y) to the focus. Write an expression for this distance.
- (c) Draw on the graph the distance from (x, y) to the directrix. Write an expression for this distance.
- (d) Use these two expressions and some algebra to find the formula for the parabola.
- (e) How might you have known, before completing the algebra, that the result would be in the form $y = ax^2 + bx + c$?
-

Problem 179 Now derive the formula for a parabola with focus at $(2, 1)$ and directrix $y = -1$.

Problem 180 Now derive the formula for a parabola with focus at $(1, -3)$ and directrix $x = 3$. How might you have known, before completing the algebra, the form of the result?

35 More Medians

We think about coordinate geometry, medians, and triangles.

Here we use coordinates to explore several ways of thinking about the medians of triangles.

Problem 181 For each set of points below, plot the points in the coordinate plane, and use a ruler to draw the triangle. Locate the midpoint of each side, and use a ruler to draw the medians. Check that the medians are concurrent, and find the coordinates of the centroid.

- (a) $A = (2, 1)$, $B = (10, 2)$, $C = (3, 6)$. Centroid: _____.
- (b) $D = (6, 6)$, $E = (9, 10)$, $F = (4, 8)$. Centroid: _____.
- (c) $G = (-1, 1)$, $H = (1, 6)$, $I = (-3, 4)$. Centroid: _____.

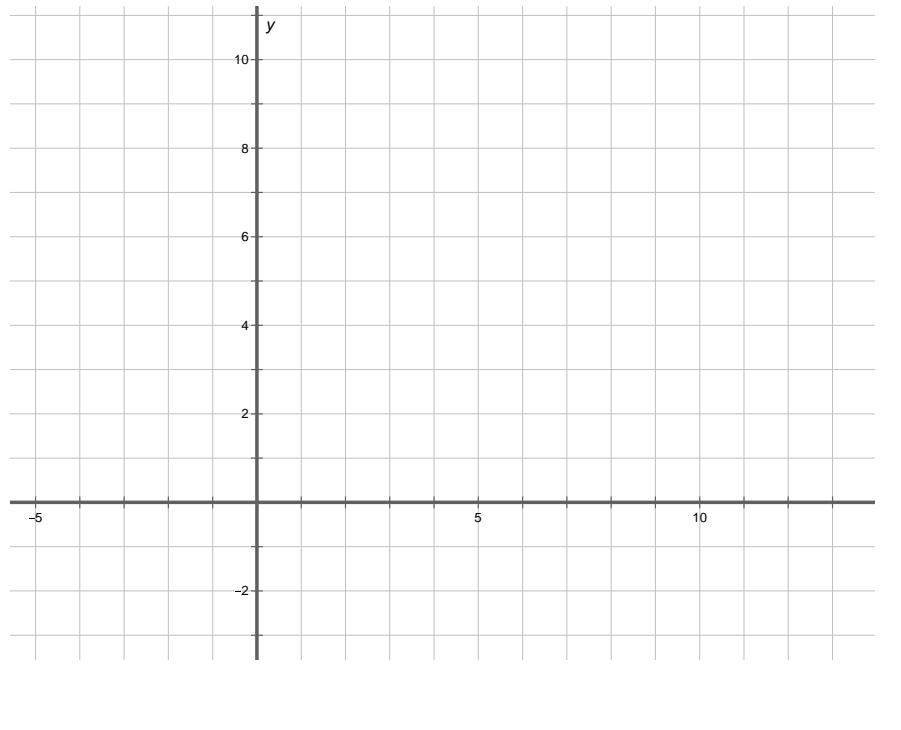

Author(s): Bart Snapp and Brad Findell

Problem 182 What do you notice about how the coordinates of the centroid depend upon the coordinates of the vertices? Make a conjecture about the centroid of a triangle with vertices at (x_1, y_1) , (x_2, y_2) , and (x_3, y_3) . Check that your formula works for all of the triangles above.

Problem 183 Imagine a triangle made of nearly weightless material with one-pound weights placed at each of the vertices, $A = (x_1, y_1)$, $B = (x_2, y_2)$, and $C = (x_3, y_3)$.

- (a) Explain why the triangle will balance on a ruler along the median to side \overline{AB} .

- (b) Explain why the triangle will continue to balance along the median when the masses at A and B are both moved to the midpoint of \overline{AB} .

- (c) Now imagine trying to balance the triangle at a single point along the median. Where will it balance? Use the phrase “weighted average” to explain your reasoning.

- (d) Use weighted-average reasoning to compute the coordinates of this balance point, assuming the vertices are $A = (x_1, y_1)$, $B = (x_2, y_2)$, and $C = (x_3, y_3)$.

Problem 184 Consider a triangle with vertices at $A = (x_1, y_1)$, $B = (x_2, y_2)$, and $C = (x_3, y_3)$.

- (a) Explain why the equation of the line containing the median from C to the midpoint of \overline{AB} can be written as follows:

$$\frac{y - y_3}{x - x_3} = \frac{y_1 + y_2 - 2y_3}{x_1 + x_2 - 2x_3}$$

- (b) From reasoning alone (i.e., without doing additional calculations) write down analogous equations for the lines containing the other two medians.

- (c) Use algebra and reasoning to show that the previously-conjectured coordinates of the centroid satisfy all three equations of lines containing medians.

- (d) Have you now proven that the medians are concurrent? Explain.

36 Constructible Numbers

We use algebra to help us understand compass and straightedge constructions.

Compass and straightedge constructions involve drawing and finding intersections of two fundamental geometric objects: lines and circles. All more complicated constructions are combinations of pieces of these.

In this activity, we explore what numbers are constructible (as lengths or distances) with compass and straightedge, assuming only that we begin with a segment of length 1. We call such numbers *constructible numbers*. First we must establish how to do arithmetic with compass and straightedge.

Arithmetic with Constructions

Problem 185 *Suppose you are given a compass and a straightedge and segments of lengths a , b , and 1.*

- (a) *How would you construct a segment of length $a + b$?*

- (b) *How would you construct a segment of length $a - b$?*

- (c) *How would you construct a segment of length ab ? (Hint: Use similar triangles.)*

- (d) *How would you construct a segment of length $a \div b$?*

- (e) *How would you construct a segment of length \sqrt{a} ? (Hint: Recall how to construct a geometric mean.)*

Problem 186 Beginning with a segment of length 1, how you might construct segments of the following lengths? Describe briefly (to your partner) the arithmetic constructions you would use, in what order, and with which numbers.

(a) $\frac{7}{5}$

(b) Any rational number, p/q

(c) $3 + 2\sqrt{5}$

(d) $\frac{3 + \sqrt{2 - \sqrt{3}}}{1 + \sqrt{5}}$

Problem 187 Based on the previous problems, if you begin with a segment of length 1, describe the set of all numbers constructible with the methods used so far.

Coordinate Constructions

With the methods so far, we can construct neither $\sqrt[3]{2}$ nor π . The question now is whether we have described the entire set of constructible numbers or whether there are additional constructions that will broaden our arithmetic and thereby enlarge the set.

For this question, we turn to coordinate constructions, which allow us to use the methods of algebra to solve geometric problems. A key habit here will be **imagining the algebra without actually doing it**—based on your extensive algebra experience with these kinds of problems.

Problem 188 Suppose you are given points (p, q) , and (r, s) with integer coordinates.

- (a) What arithmetic operations are involved in finding an equation $ax + by = c$ of the line containing these points?
- (b) What can you conclude about the numbers a , b , and c ?
- (c) What if you begin with points that have coordinates that are rational numbers?

Problem 189 Suppose you are given equations of the form

$$ax + by = c$$

$$dx + ey = f$$

where a , b , c , d , e , and f are all integers.

- (a) What kind of geometric objects do these equations describe in the xy -plane?
- (b) What arithmetic operations would you use to solve the equations simultaneously?
- (c) What can you conclude about the numbers x and y that are the (simultaneous) solutions of these equations?
- (d) How will your answers change if a , b , c , d , e , and f are all rational numbers?

37 Constructible Numbers, Part 2

We continue to use algebra to understand compass and straightedge constructions.

Problem 190 Suppose you are given points (h, k) , and (p, q) with integer coordinates?

- (a) Write an equation of the circle with center (h, k) and containing the point (p, q) .
- (b) What arithmetic operations were involved in writing your equation of the circle?
- (c) What can you conclude about the numbers that are coefficients in your equation?

Problem 191 Solve the following equations simultaneously

$$(x - 3)^2 + (y - 2)^2 = 14$$

$$y = x + 4$$

Problem 192 Solve the following equations simultaneously

$$(x - 3)^2 + (y - 2)^2 = 18$$

$$y = x + 5$$

Problem 193 Solve the following equations simultaneously

$$(x - 3)^2 + (y - 2)^2 = 12$$

$$y = x + 4$$

Problem 194 Solve the following equations simultaneously

$$(x - 3)^2 + (y + 2)^2 = 4$$

$$(x - 1)^2 + (y - 2)^2 = 9$$

Problem 195 Solve the following equations simultaneously

$$(x - 3)^2 + (y + 2)^2 = 4$$

$$(x + 1)^2 + (y - 2)^2 = 9$$

Problem 196 Suppose you are given equations of the form

$$x^2 + ax + y^2 + by = c$$

$$x^2 + dx + y^2 + ey = f$$

where $a, b, c, d, e,$ and f are all integers.

- (a) What kind of geometric objects do these equations describe in the xy -plane?
- (b) What arithmetic operations would you use to solve the equations simultaneously?
- (c) What can you conclude about the numbers x and y that are the (simultaneous) solutions of these equations?
- (d) How will your answers change if $a, b, c, d, e,$ and f are all rational numbers?

Problem 197 Based on the previous problems, if you begin with a coordinate system with only integer coordinates, how would you describe the set of all numbers (coordinates) that are constructible via lines and circles?

Problem 198 Considering that all compass and straightedge constructions are about lines, circles, and their intersections, what do your results about coordinate constructions imply about compass and straightedge constructions?

Problem 199 Name some numbers that are **not constructible** with compass and straightedge.

38 Impossibilities

We investigate which numbers are constructible with compass and straightedge alone.

The idea that some numbers are not constructible is exactly what was needed to address several problems first posed by the Greeks in antiquity, such as doubling the cube and trisecting an angle. In a paper published in 1837, Pierre Wantzel used algebraic methods to prove the impossibility of these geometric constructions.

Problem 200 *Suppose you have a square of side length s and you want to “double the square.” In other words, you want to construct a square with **twice the area**.*

- (a) *What is the side length of the desired square? Explain your reasoning.*
- (b) *Is this side length constructible? Explain.*

Problem 201 *Suppose you have a cube of side length s and you want to “double the cube.” In other words, you want to construct a cube with **twice the volume**.*

- (a) *What is the side length of the desired cube? Explain your reasoning.*
- (b) *Is this side length constructible? Explain.*

Problem 202 You may remember some double angle formulas from trigonometry. There are also triple angle formulas. For example, for any angle ϑ , $\cos 3\vartheta = 4 \cos^3 \vartheta - 3 \cos \vartheta$.

- (a) Write the above triple angle formula for $\vartheta = 20^\circ$.
- (b) Explain why $x = \cos 20^\circ$ must be a root of the polynomial $8x^3 - 6x - 1$.
- (c) Explain how the rational root theorem implies that this polynomial has no linear factors.
- (d) Explain why this polynomial must therefore be irreducible over the rational numbers.
- (e) You may recall from Math 1165 that some methods of solving cubic equations involve extracting cube roots. What does this imply about trisecting angles?
- (f) You may recall, from earlier this semester, discussing a method for trisecting an angle with paper folding. What does that method imply about the relationship between the numbers that are constructible by paper folding and those that are constructible by compass and straightedge? Explain.

Part V

Functions

39 Area and Perimeter

We study the relationship between area and perimeter.

Problem 203 You have been asked to put together the dance floor for your sister's wedding. The dance floor is made up of 24 square tiles that measure one meter on each side.

- (a) Experiment with different rectangles that could be made using all of these tiles, and record your data in a table.
- (b) Draw a graph of your data. Describe patterns in the data, as seen in the table or graph.
- (c) Can we connect the dots in the graphs? Explain.
- (d) How might we change the context so that the dimensions can be other than whole numbers? In the new context, how would the previous answers change?

Problem 204 Suppose the dance floor is held together by a border made of thin edge pieces one meter long.

- (a) What determines how many edge pieces are needed? Explain.
- (b) Make a graph showing the perimeter vs. length for various rectangles with an area of 24 square meters.
- (c) Describe the graph. How do patterns that you observed in the table show up in the graph?
- (d) For perimeter and length, is either one a function of the other? Explain what that means.
- (e) Which design would require the most edge pieces? Explain.
- (f) Which design would require the fewest edge pieces? Explain.
- (g) If the context allows dimensions other than whole numbers, how would the previous answers change?

Problem 205 Suppose you had begun with a different number of floor tiles, such as 30, 21, or 19, or 36.

- (a) In general, describe the rectangle with whole-number dimensions that has the greatest perimeter for a fixed area.
- (b) If the context does not require whole-number dimensions, describe the rectangle with the least perimeter for a fixed area.

Problem 206 The previous problems were about rectangles with constant area and changing perimeter.

- (a) Make up a problem about rectangles with whole-number dimensions, constant perimeter, and changing area.
- (b) Make a table of length, width, perimeter, and area for these rectangles.
- (c) Draw graphs of width versus length and area versus length for your rectangles.
- (d) Now modify the context and your graphs to allow dimensions that are not whole numbers.
- (e) Which rectangle will have a maximum area? Explain.
- (f) Which rectangle will have a minimum area? Explain.

Problem 207 So far we have considered rectangles with fixed area and those with fixed perimeter. What about fixing the width or the length? Since they behave in much the same way, let's fix the width.

- (a) Make up a problem about rectangles with constant width and changing area and perimeter.
- (b) Make a table of length, width, perimeter, and area for these rectangles.
- (c) Draw graphs of area versus length and perimeter versus length for your rectangles.

Problem 208 What types of functions did you see in the previous problems? Complete the following sentences with types of functions. (Note: If two functions are the same type, write answers that distinguish them from each other.)

- (a) Fixed width: area vs. length is a _____.
 - (b) Fixed width: perimeter vs. length is a _____.
 - (c) Fixed perimeter: width vs. length is a _____.
 - (d) Fixed perimeter: area vs. length is a _____.
 - (e) Fixed area: width vs. length is a _____.
 - (f) Fixed area: perimeter vs. length is a _____.
-

Problem 209 Explain how and where you saw the following advanced algebra ideas in the above problems:

- (a) Domain, range and “limiting cases”
 - (b) Rates of change, maxima, minima, and asymptotic behavior
 - (c) Generalizing from a specific to a generic fixed quantity
 - (d) Equation solving with several variables
-

40 Reading Information from a Graph

We analyze graphs of functions.

On the next page is the graph of a function called $h(t)$, which represents the distance (in miles) and direction (east = positive, west = negative) Johnny is from home t hours after noon. It does not have a simple formula, so don't try to find one. Answer the following questions about h , briefly explaining how you obtained your answer(s):

Problem 210 *On the given graph of h , what are the least and greatest values of t ? What are the least and greatest values of $h(t)$? What do these answers say about Johnny?*

Problem 211 *Evaluate the following expressions: $h(0)$, $h(3)$, and $h(-3)$. What do each of these say about Johnny?*

Problem 212 *For each of the following, solve for t (i.e., find all the values of t that make the statement true). Describe what you did with the graph to determine the solutions. Where possible, interpret the statement and its solutions in terms of Johnny's travels.*

- (a) $h(t) = 0$
 - (b) $h(t) = 3$
 - (c) $h(t) \leq 3$
 - (d) $h(t) = h(4.5)$
 - (e) $h(t) = t$
 - (f) $h(t) = -t$
 - (g) $h(t) = h(-t)$
 - (h) $h(t) = -h(-t)$
 - (i) $h(t + 1) = h(t)$
 - (j) $h(t) + 1 = h(t)$
-

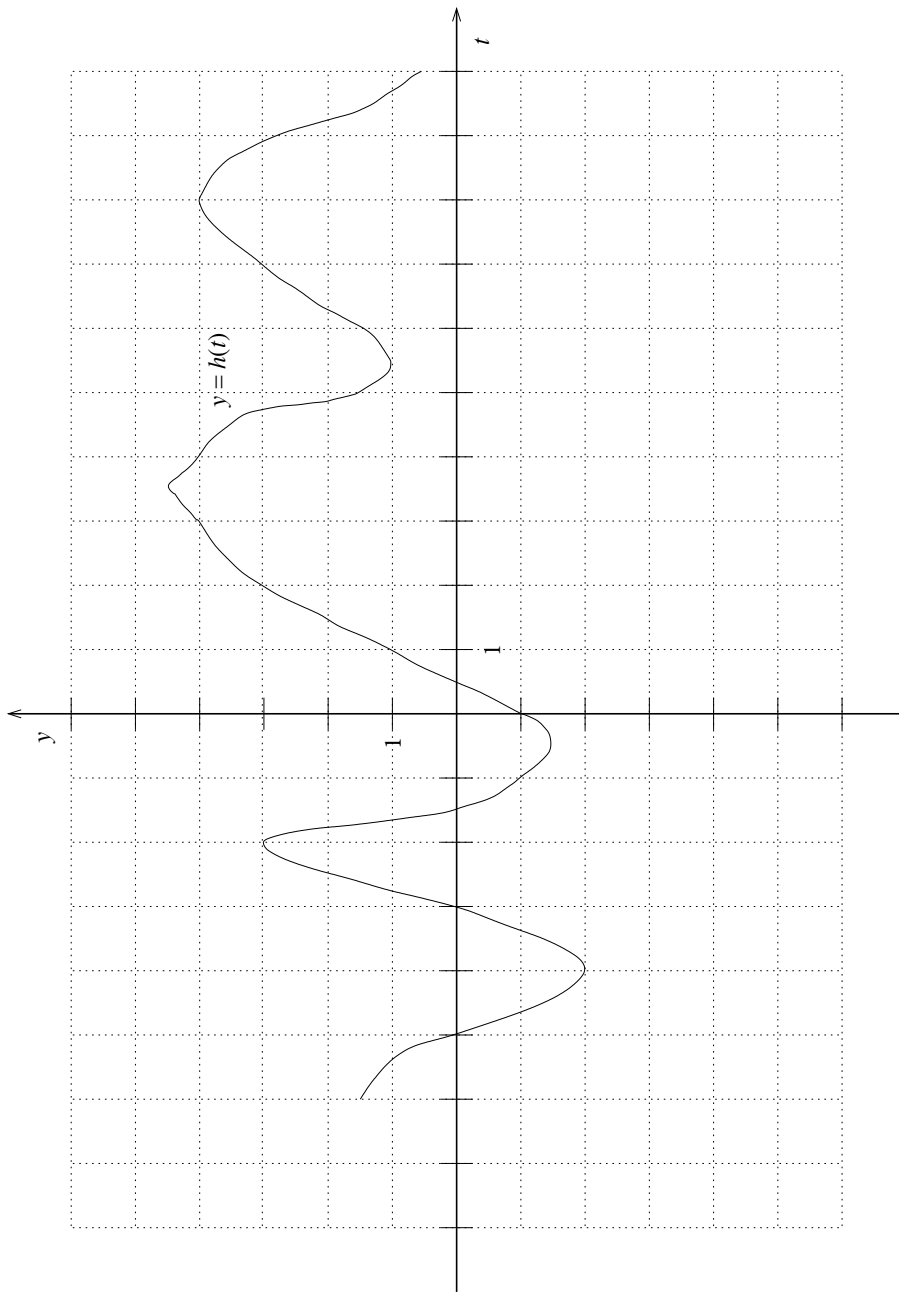

41 Circular Trigonometry

We investigate how trigonometric functions relate to circles.

As we have seen, right triangle trigonometry is restricted to acute angles. But angles are often obtuse, so it is quite useful to extend trigonometry to angles greater than 90° . Here is one approach: Place the angle with the vertex at the origin in the coordinate plane and with one side of the angle (the initial side) along the positive x -axis. Measure to the other side of the angle (the terminal side) as a counter-clockwise rotation about the origin.

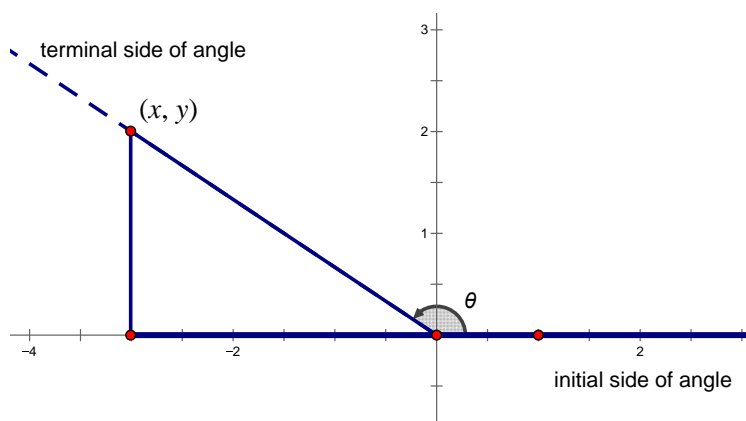

If we choose a point on the terminal side of this angle, we can draw what is called *reference triangle* by dropping a perpendicular to the x -axis. Then we can use the values of x , y , and r from this triangle, just as before. What is different in this picture is that x is negative, as will be the case for any angle with a terminal side in the second quadrant.

Problem 213 Draw a picture and use it to find the following values:

- (a) $\sin 135^\circ =$
- (b) $\cos 135^\circ =$
- (c) $\tan 135^\circ =$

Problem 214 Draw a picture and use it to find the following values:

(a) $\sin 150^\circ =$

(b) $\cos 150^\circ =$

(c) $\tan 150^\circ =$

Problem 215 For some angles, the reference triangle is not actually a ‘triangle,’ but that’s okay. Draw pictures to demonstrate the following:

(a) $\sin 90^\circ =$

(b) $\cos 90^\circ =$

(c) $\tan 90^\circ =$

(d) $\sin 180^\circ =$

(e) $\cos 180^\circ =$

(f) $\tan 180^\circ =$

Because angles are often about rotation, angles greater than 180° can make sense, too. And negative angles can describe rotation in the opposite direction. If we consider the angle to change continuously, then rotation about the origin creates a situation that repeats every 360° . This repetition provides the foundation for modeling lots of repetitive (periodic) contexts in the real world. For this modeling, we need *circular trigonometry*, which turns out to be much cleaner if (1) angles are measured not in degrees but in a more “natural” unit, called radians; and (2) we use *the unit circle*, which is a circle of radius 1 centered at the origin.

Problem 216 Below is the unit circle with special angles labeled in degrees, radians, and with coordinates.

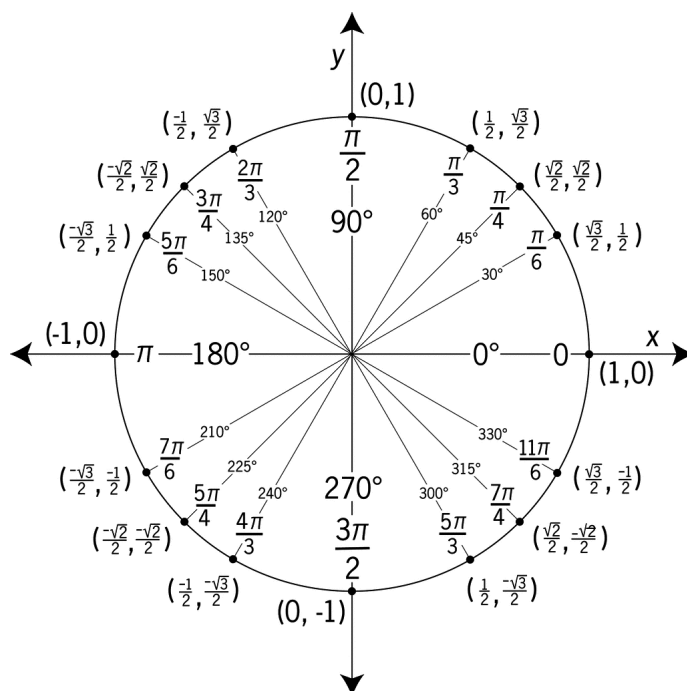

• CCSS F-TF.2. Explain how the unit circle in the coordinate plane enables the extension of trigonometric functions to all real numbers, interpreted as radian measures of angles traversed counter-clockwise around the unit circle.

- Explain what the various numbers mean in this unit circle.
- Use the unit circle to make a table showing (1) angle in degrees, (2) angle in radians, (3) sine of the angle, and (4) cosine of the angle.
- Use your table to draw a graph of $\sin \vartheta$ versus ϑ .
- Use your table to draw a graph of $\cos \vartheta$ versus ϑ .
- Explain why it makes sense to connect the dots.
- Extend your graphs to angles greater than 360° , and use the unit circle to explain why your extension makes sense.
- Extend your graphs to angles less than 0° , and use the unit circle to explain why your extension makes sense.

42 Parametric Equations

We investigate parametric functions.

Definition 8. When graphs are given by parametric equations, the coordinates x and y may be given as functions of t , often thought of as “time.” To begin graphing parametric equations, make a table of values for t , x , and y , and then plot the order pairs (x, y) .

Problem 217 Consider the following parametric equation about points that vary with t :

$$(x, y) = (2t + 3, -t - 4).$$

To see the individual coordinates as functions of time, this equation can also be written as a pair of equations, as follows:

$$x(t) = 2t + 3 \quad y(t) = -t - 4 \quad (1)$$

- (a) Graph the equation. It might help to note various values of t on your graph.
- (b) Describe the graph and explain why it looks the way it does.
- (c) Locate the points corresponding to $t = \frac{2}{3}, \frac{5}{4}, 3.14$, and π .
- (d) Why is it okay to connect the dots? Consider what happens to the x and y coordinates near and between points you have already plotted.
- (e) What are the input values for this parametric equation?
- (f) What are the output values for this parametric equation?

Definition 9. A vector has both direction and magnitude (i.e., length). In this course, vectors will often be given as ordered pairs, and they may be drawn or imagined as arrows from the origin to the given point, but the position of a vector is unimportant.

Problem 218 The vector $(3, 2)$ can be represented as an arrow from $(0, 0)$ to $(3, 2)$. Explain why an arrow from $(1, 6)$ to $(4, 8)$ also describes the vector $(3, 2)$.

Problem 219 What vector may be represented by an arrow from $(6, 4)$ to $(2, 1)$?

Problem 220 Consider the equation $(x, y) = (2, 1) + t(-1, 3)$.

- Graph the equation.
 - Use the ideas of a starting point and a direction vector to explain why the graph looks the way it does.
 - Pick an arbitrary point on your graph and describe how to arrive at that point using the starting point and scaling the direction vector.
-

Problem 221 Graph the equation $(x, y) = (2, 1) + t(2, -6)$. Compare and contrast this problem with the previous problem.

Problem 222 Write a parametric equation for the line containing $(-3, 2)$ and $(2, 1)$.

Problem 223 Write a parametric equation for the line containing the points (a, b) and (c, d) .

Problem 224 Consider the line containing the points $A = (2, 4)$ and $B = (-1, 8)$.

- (a) Find the coordinates of the point $2/3$ of the way from A to B .
 - (b) Find the coordinates of the point $5/4$ of the way from A to B .
 - (c) Find the coordinates of the point p/q of the way from A to B .
 - (d) What would it mean for p/q to be greater than 1? Explain.
 - (e) What would it mean for p/q to be negative? Explain.
 - (f) What geometric object will result if p/q varies through all possible rational numbers? Explain.
 - (g) Find the coordinates of the point p/q of the way between (a, b) and (c, d) .
-

43 Parametric Plots of Circles

We explore parametric plots of circles.

In this activity we'll investigate parametric plots of circles.

Problem 225 *One problem with the standard form for a circle, even the form for the unit circle*

$$x^2 + y^2 = 1,$$

is that it is somewhat difficult to find points on the circle. We claim that for any value of t ,

$$x(t) = \cos(t)$$

$$y(t) = \sin(t)$$

will be a point on the unit circle. Can you give me some explanation as to why this is true? Two hints, for two answers: The unit circle; The Pythagorean identity.

Problem 226 *Another way to think about parametric formulas for circles is to imagine*

$$x(\vartheta) = \cos(\vartheta)$$

$$y(\vartheta) = \sin(\vartheta)$$

where ϑ is an angle. What is the connection between value of ϑ and the point $(x(\vartheta), y(\vartheta))$?

Problem 227 One way to think about parametric formulas for circles is to imagine

$$\begin{aligned}x(t) &= \cos(t) \\y(t) &= \sin(t)\end{aligned}$$

as “drawing” the circle as t changes. Starting with $t = 0$, describe how the circle is “drawn.” Make a table of values of t , x , and y . Use values of t that are special angles. Includes values of t that are negative as well as some values of t that are greater than 2π .

Problem 228 One day you accidentally write down

$$\begin{aligned}x(t) &= \sin(t) \\y(t) &= \cos(t)\end{aligned}$$

Again, make a table of values of t , x , and y . What happens now? Do you still get a circle? How is this different from what we did in the previous question?

Problem 229 Do the formulas

$$\begin{aligned}x(t) &= \cos(t) \\y(t) &= \sin(t)\end{aligned}$$

define a function? Discuss. Clearly identify the domain and range as part of your discussion. Remember, the domain is the set of input values and the range is the set of output values.

Problem 230 Reason with your previous tables of x - and y -values to determine the graph of the following parametric equations.

$$x(t) = 2 \cos(t) + 3$$

$$y(t) = 2 \sin(t) - 4$$

Explain your reasoning.

Problem 231 Now we will go backwards. The standard form for a circle centered at a point (a, b) with radius c is given by

$$(x - a)^2 + (y - b)^2 = r^2.$$

Explain why this makes perfect sense from the definition of a circle.

Problem 232 Here are three circles

$$(x - 1)^2 + (y + 2)^2 = 4^2 \quad (x + 4)^2 + (y - 2)^2 = 8 \quad x^2 + y^2 - 4x + 6y = 12.$$

Convert each of these circles to parametric form.

44 Eclipse the Ellipse

We'll investigate parametric plots of ellipses and other curves.

Problem 233 Recall that for $0 \leq t < 2\pi$

$$x(t) = \cos(t)$$

$$y(t) = \sin(t)$$

gives a parametric plot of a unit circle. Describe the plot of

$$x(t) = 3 \cos(t)$$

$$y(t) = \sin(t)$$

for $0 \leq t < 2\pi$.

Problem 234 Now describe the plot of

$$x(t) = 2 \cos(t)$$

$$y(t) = 5 \sin(t)$$

for $0 \leq t < 2\pi$.

Problem 235 We claim that an ellipse centered at the origin is defined by points (x, y) satisfying

$$\left(\frac{x}{a}\right)^2 + \left(\frac{y}{b}\right)^2 = 1.$$

Are the parametric curves we found above ellipses? Explain why or why not.

Problem 236 Here we have some plots showing two concentric circles and an ellipse that touches both.

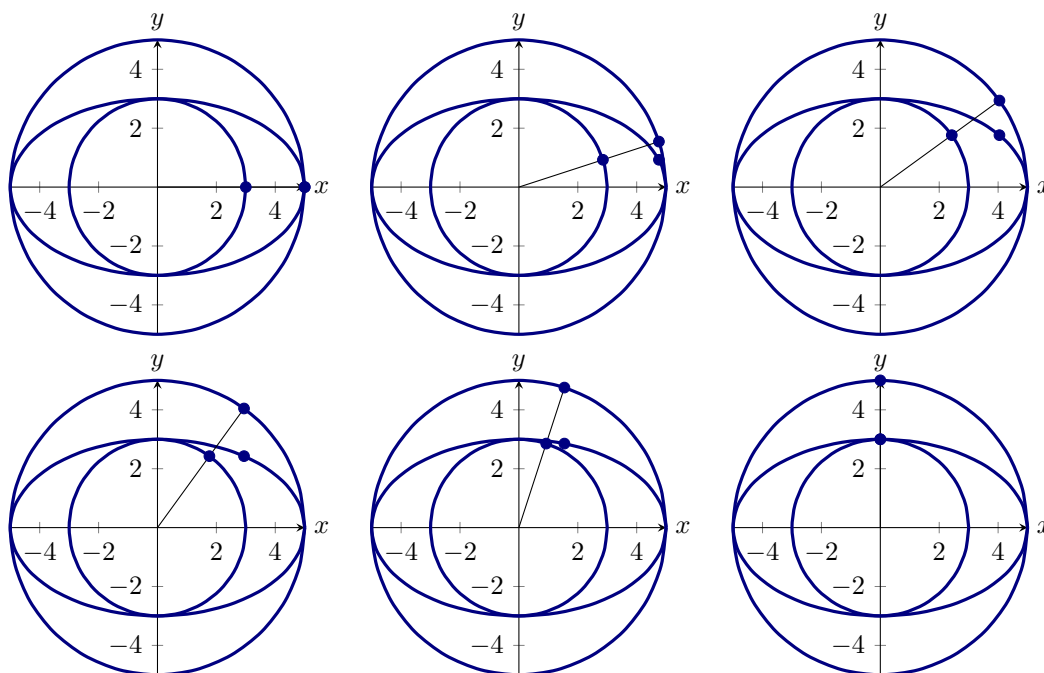

- Can you guess parametric formulas for the circles and for the ellipse?
- Do you notice anything about the dots in the pictures? Can you explain why this happens?
- Can you give a compass and straightedge construction that will give you as many points on a given ellipse as you desire? Give a detailed explanation.

Problem 237 Can you give a parametric formula for this cool spiral?

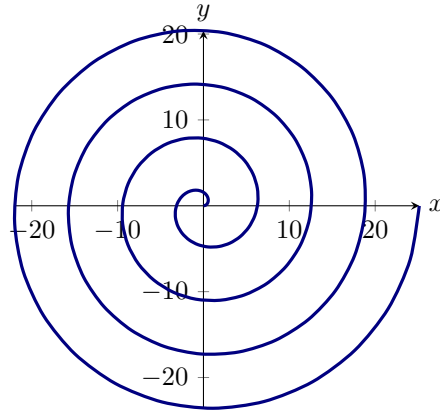

Problem 238 Remind me once more, do the formulas that produce these plots define functions? Discuss. Clearly identify the domain and range as part of your discussion.

Part VI

City Geometry

45 Taxicab Distance

We explore geometry with a noneuclidean distance.

In this activity, we explore *City Geometry*, where points are Euclidean points, given with coordinates; lines are Euclidean lines, defined with equations or by two points, as in Euclidean coordinate geometry; and angles are Euclidean angles. Distance, however, is measured according to the path a taxicab might travel. Let's get started.

Problem 239 *Suppose we are in a city that is neatly laid out in blocks of two-way streets, with streets running north-south and east-west, and suppose we want to travel from point A to point B in the figure below.*

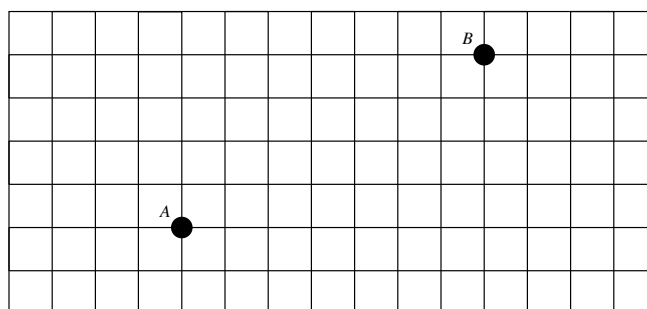

- (a) *What is the taxicab distance, measured in city blocks, from point A to point B? (Do we mean the shortest distance, the longest distance, or something else?)*

- (b) *Is there a single shortest path for the taxi to take? Explain.*

- (c) *Let $A = (1, 2)$. What would be the coordinates of B?*

- (d) Describe a calculation that yields the taxicab distance between points A and B .
- (e) Suppose the taxicab may travel on alleys also running north-south and east-west. Better yet, suppose the taxicab can create alleys wherever they would be most useful, except that they must still run north-south or east-west. What then would be the taxicab distance from A to B ? Explain.
- (f) Based on your reasoning, given points $P = (x_1, y_1)$ and $Q = (x_2, y_2)$, write a formula for, $d_T(P, Q)$, the taxicab distance between points P and Q . Check that it works for several pairs of points.

46 Understanding and Using Absolute Value

We think about absolute value.

Problem 240 *True or False (and explain)*

- (a) $-x$ is negative
- (b) $\sqrt{9} = \pm 3$
- (c) $\sqrt{x^2} = x$
- (d) $\sqrt{x^2} = |x|$
- (e) If $|x| = -x$ then x is negative or 0.

Problem 241 *Let's consider circles in city geometry. Hint: First, remind yourself how to use the definition of circle and the distance formula in Euclidean coordinate geometry to derive the equation of a Euclidean circle with radius r and center (a, b) .*

- (a) *Use the taxicab distance formula to derive the equation of a city-geometry circle with radius r and center (a, b) .*
- (b) *Write the equation of a city-geometry circle with radius 1, centered at the origin, and draw a graph of this city-geometry circle.*

To better understand the equation of this city-geometry circle, we need to firm up the idea of absolute value.

Problem 242 Consider the following attempts to characterize the absolute value function.

$$|x| \text{ is the "magnitude" of } x\text{—the size of } x, \text{ ignoring its sign.} \quad (2)$$

$$|x| \text{ is the distance from the origin to } x. \quad (3)$$

$$|x| = \sqrt{x^2} \quad (4)$$

$$|x| = \begin{cases} x & \text{if } x \geq 0 \\ -x & \text{if } x < 0 \end{cases} \quad (5)$$

- (a) Which characterization is the definition of the absolute value function?
- (b) Are the other characterizations of the absolute value function equivalent to the definition? Explain.
- (c) Use one or more of these characterizations to develop meanings for $|x - a|$ and $|a - x|$ where a is a constant.
- (d) Use one or more of these characterizations to explain the solution(s) to $|x - 5| = 8$.
- (e) What are the benefits of using more than one characterization of this idea?

Problem 243 Use the piecewise characterization of the absolute value function to explain why the equation $|x| + |y| = 1$ has the graph that it does. (Hint: Consider various cases, depending upon the sign of x and the sign of y .)

47 The Path Not Taken

We study shortest paths in city geometry.

In Euclidean geometry, there is a unique shortest path between two points. Not so in city geometry, here you have many different choices. Let's investigate this further.

Problem 244 *Place two points 5 units apart on the grid below. How many paths are there that follow the grid lines? Note, if your answer is 1, then maybe you should pick another point!*

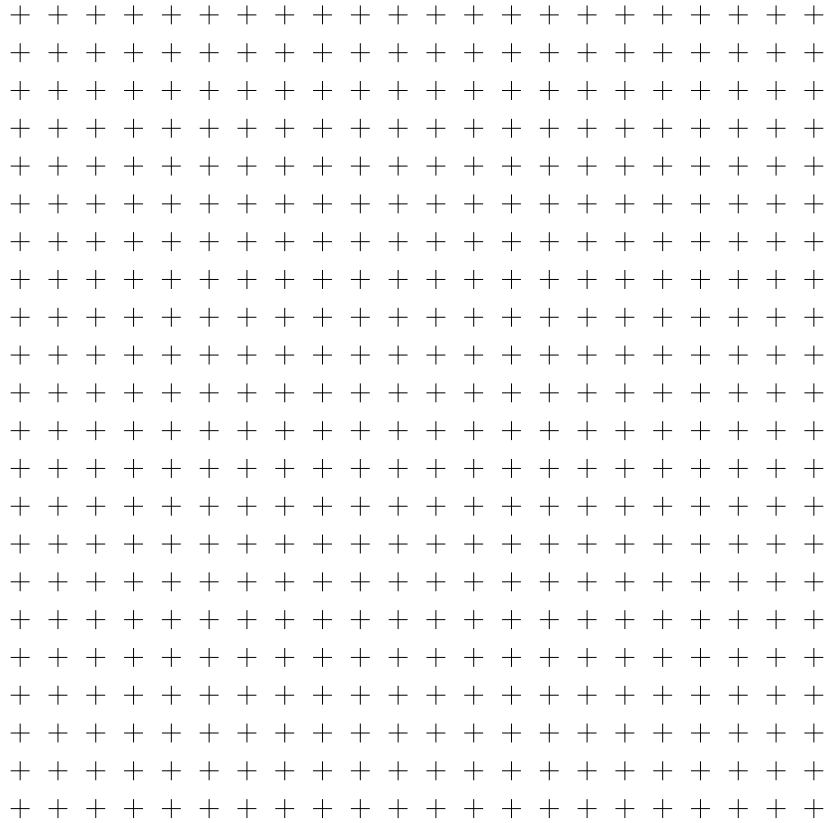

Be sure to demand that your results are shared with the rest of the class.

Problem 245 Do the first problem again, except for points that are 4 units apart and then for points that are 6 units apart. What do you notice? Can you explain this?

Problem 246 Construct a chart showing your findings from your work above, and other findings that may be relevant.

Problem 247 Suppose you know how many paths there are to all points of distance n away from a given point. Can you easily figure out how many paths there are to all points of distance $n + 1$ away? Try to explain this in the context of paths in city geometry.

48 Midsets Abound

We introduce and investigate midsets.

Definition 10. *Given two points A and B , their **midset** is the set of points that are an equal distance away from both A and B .*

Problem 248 *Draw two points in the plane A and B . See if you can sketch the Euclidean midset of these two points.*

Problem 249 *See if you can use coordinate constructions to find the equation of the midset of two points A and B . If necessary, set $A = (2, 3)$ and $B = (5, 7)$.*

Problem 250 *Now working in city geometry, place two points and see if you can find their midset.*

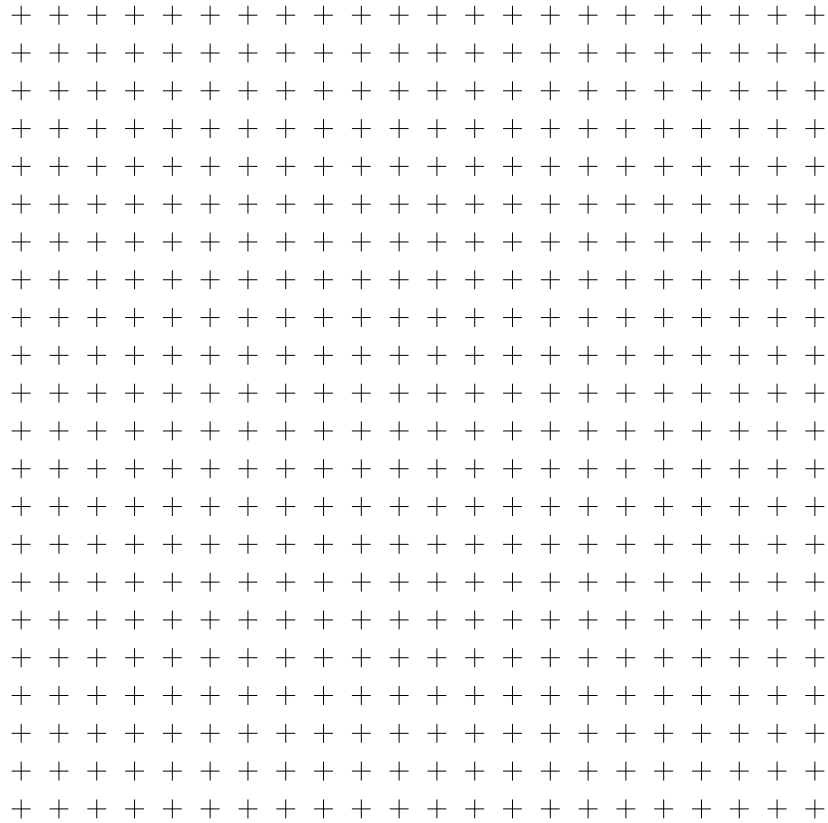

Problem 251 *Let's try to classify the various midsets in city geometry:*

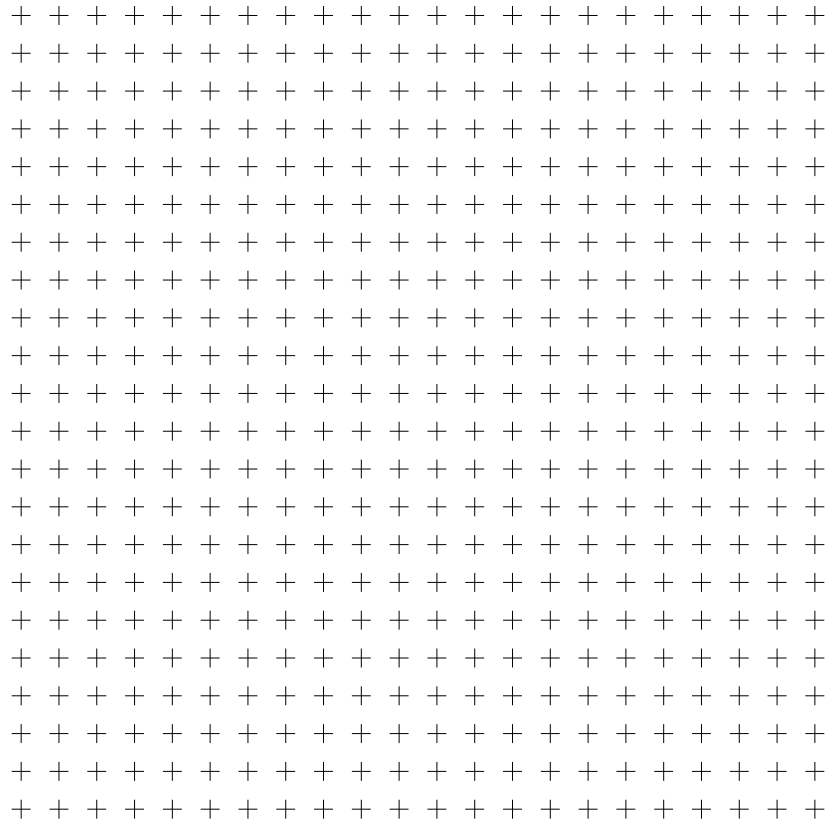

49 Tenacity Paracity

We investigate city geometry parabolas.

Problem 252 *Remind me again, what is the definition of a parabola?*

Problem 253 *Use the definition of a parabola and taxicab distance to sketch the city geometry parabola when the focus is the point $(2, 1)$ and the directrix is $y = -3$.*

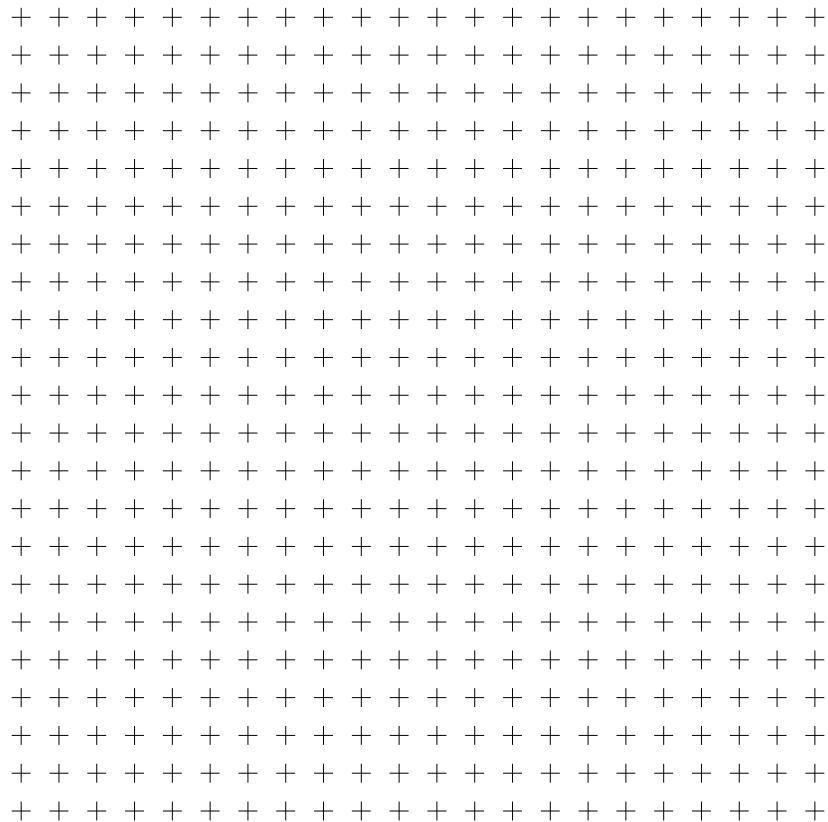

Author(s): Bart Snapp and Brad Findell

Problem 254 *Comparing geometries with algebra.*

- (a) *Use coordinate constructions to write an equation for the Euclidean geometry parabola with its focus at $(2, 1)$ and its directrix being the line $y = -3$. (Hint: No need to simplify. Just use the definition and set the distances equal to one another.)*

- (b) *Use your taxicab distance formula to write an equation for the city geometry parabola with its focus at $(2, 1)$ and its directrix being the line $y = -3$.*

- (c) *Compare and contrast the two equations.*

- (d) *Use algebra of absolute value to show that the graph in the previous problem is the correct graph. (Hint: Consider three cases: $y > 1$, $-3 \leq y \leq 1$, and $y < -3$.)*

Problem 255 Sketch the city geometry parabola when the focus is the point $(4, 4)$ and the directrix is $y = -x$.

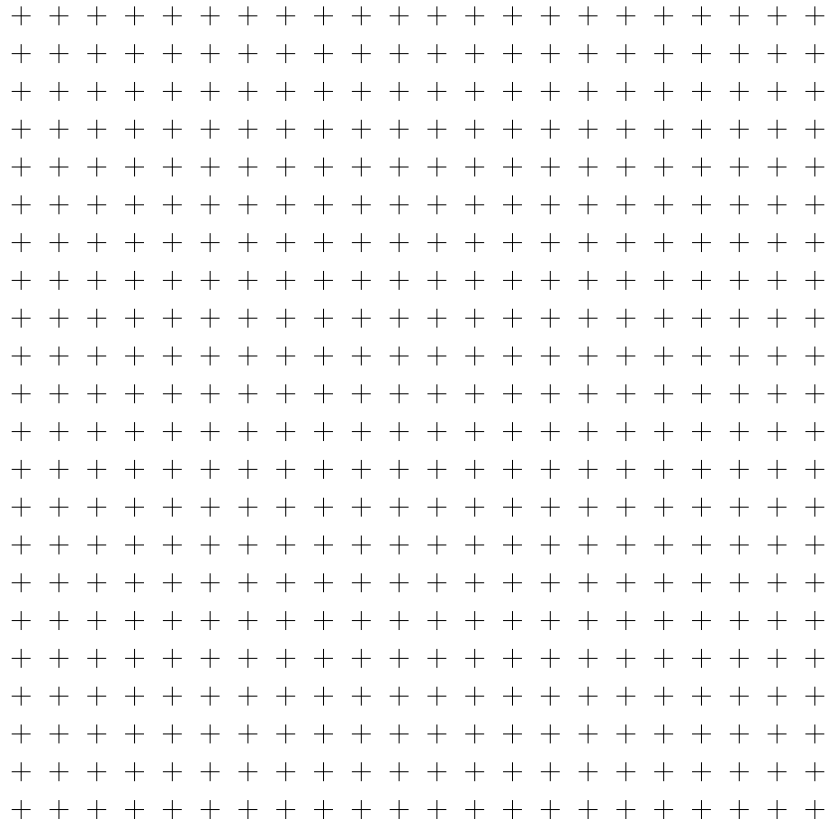

Problem 256 Sketch the city geometry parabola when the focus is the point $(0, 4)$ and the directrix is $y = x/3$.

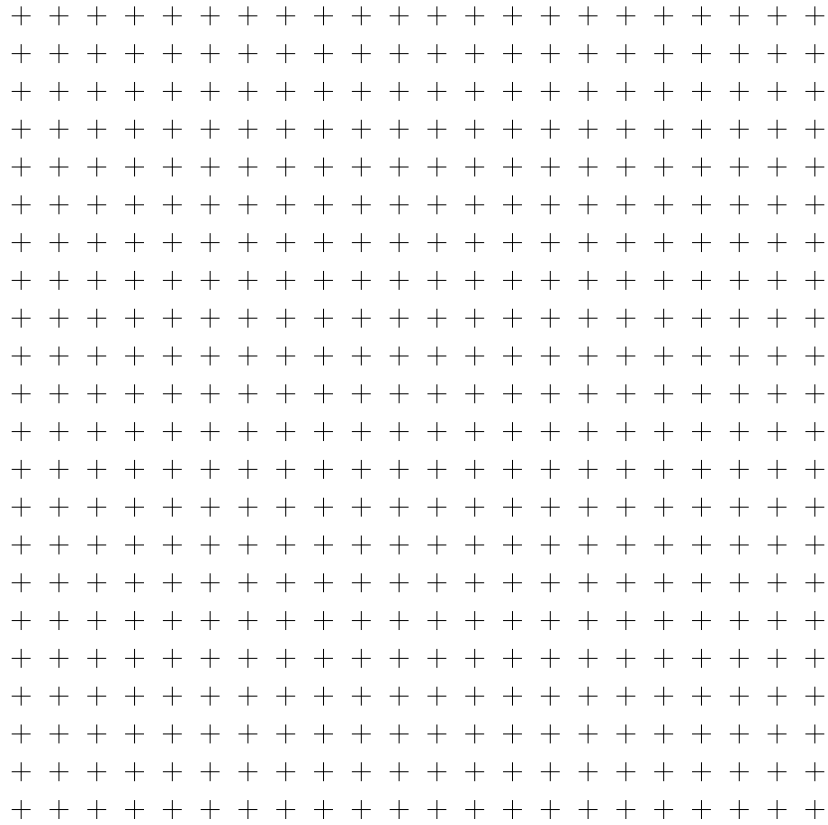

Problem 257 *Explain how to find the distance between a point and a line in city geometry.*

Problem 258 *Give instructions for sketching city geometry parabolas.*